

THE  
NATIONAL  
QUARTER  
PONY  
ASSOCIATION, INC.



RULES  
AND  
REGULATIONS

REVISED 2024

## **FORWARD**

The National Quarter Pony Association, Inc. was organized in 1975 to record and preserve pedigrees of Quarter Ponies. The NQPA provides information to its members and the general public on matters pertaining to shows, contests, and projects designed to improve the breed.

This handbook contains Corporation By-Laws Rules and Regulations of Registration, Rules and Regulations of Shows and Contests.

For additional information, contact:  
National Quarter Pony Association, Inc.  
P.O. Box 171  
Melrose, Ohio 45861  
419-594-2968

## **NQPA OFFICERS**

Heather Echler	President (419-494-4583)
Bridget Heasley	Vice Pres
Wendy Stephey	Sec./Treas. (419) 594-2968
	Points Secretary

## **NQPA DIRECTORS**

Sharon (Sam) Eison	New Lexington, Ohio
Victoria Hill	Brazil, Indiana
Taryn Homier	Cloverdale, Ohio
Raygan Moline	Bellefontaine, Ohio
Jamie Rosebrock	Napoleon, Ohio
Phil Tucker	Cloverdale, Ohio

## **NQPA DIRECTORS AT LARGE**

Bruce Shaver  
R J Lynam

## **NQPA DIRECTORS EMERITUS**

Deanna Jones	Ohio
Christie King-Moree	Kokomo, IN
R.J. Lynam	Sunbury, Ohio

Email for NQPA [nationalquarterpony@gmail.com](mailto:nationalquarterpony@gmail.com)

<b>TABLE OF CONTENTS</b>	<b>Rule #</b>	<b>Page #</b>
Attire	27	40
Attire, Ranch Pleasure	81	79,80
Barrel Racing	87	109
Breeder/Breeding Certificate	14	33
Certificate of Achievement	32	43
Class Routine	23	37
Conduct	21	36
Contest Division	87	106
Disciplinary Procedure	3	17
Disqualification	24	37,38
Down and Back	87	110
Egg & Spoon	79	78
English Equitation	64	63
English Performance	63	63
English Pleasure (Hunt Seat)	65	63
Equipment, Optional	28	40
Equipment, Prohibited	29	41
Fees	20	35
Flag Race	87	111
Free Style Reining	85	104
FUTURITY	59	57,58,59
General Notice Procedure	4	18
Generation Horsemanship	80	79
Ground Roping	78	78
Halter Competition	30	41
Halter Division	60	59,60
Honor Roll	35	44
Hunter Hack	66	64,65,66, 67,68,69
In Hand Trail	77	77
Inspectors	5	18
Judges	7	19,20,21
Keyhole (Two versions)	87	114,115
Lead Line	74	74
Leases	17	34
LONGE LINE	61	60,61
Membership	1	14,15,16
Naming of Pony	15	33
NQPA Bronze Century Awards	37	44
NQPA Champion Awards	41	45
NQPA English Performance Award	55	52,53
NQPA (Grandpa Red)		
Contesting Award	54	50,51

<b>TABLE OF CONTENTS</b>	<b>Rule#</b>	<b>Page#</b>
		<b>(continued)</b>
NQPA Futurity and Maturity	59	57,58,59
NQPA Gold Award	39	45
NQPA "Hes Top Shelf " Free Style Reining Award	56	54
NQPA High Point Contest	51	47
NQPA High Point Gelding	45	46
NQPA High Point Hunter Under Saddle	46	46
NQPA High Point Mare	44	46
NQPA High Point Overall Pony		
(PONY OF THE YEAR)	52	47
NQPA High Point Ranch/Ranchmanship		
	48	47
NQPA High Point Reining	49	47
NQPA High Point Showman	50	47
NQPA High Point Stallion	43	46
NQPA High Point Western Pleasure		
	47	46
NQPA Medallion Award	34	44
NQPA "MGW Bit O Crème Trail Challenge		
	57	55
NQPA PEE WEE	74	74,75
NQPA Platinum Award	40	45
NQPA RIDER RECOGNITION PROGRAM	86	105
NQPA Show Payment Policy	10	29
NQPA Silver Award	38	44
NQPA Superior Award	42	46
NQPA Supreme Event Champion Award A		
	36	44
NQPA Supreme Showman Award B.		
	36	44
NQPA TUF N TUCKER	58	56
NQPA Versatility Program Award		
	53	48,49
NQPA World Point System		116
NQPA Youth Association (NQPYA)		
	9	23,24,25 26,27,28

<b>TABLE OF CONTENTS</b>	<b>Rule #</b>	<b>Page #</b>
<b>(continued)</b>		
Optional Equipment	28	40
Performance Classes	31	42
Pleasure Driving	73	73
Points	26	39,40
Pole Bending	87	107
Prohibited Equipment	29	41
Protest	19	35
Pylon Alley	87	113
Ranchmannship	82	81,82,83,84
Ranch Pleasure	81	79,80
Register of Merit	33	43
Registration Criteria	12	30,31,32
Reining	84	91,92,93,94, 95,96,97,99, 100,101,102,103
Reins	69	72
Show Approval	25	38,39
Show Eligibility	22	36
Show Payment	10	29
Show Stewards	6	19
Showmanship Division	62	62
Speedball	87	112
Stallion Breeding Report	13	32
Stakes	87	108
State Charters	8	22
Stud Book	11	29
Surrender of Certificate	18	34
Trail Walk –Trot {Beginner}	75	75
Trail	76	76
Transfers	16	33
Violations	2	16,17
Walk Trot Horsemanship	70	72
Western Horsemanship	71	72
Western Performance	68	71
Western Pleasure	72	72
Western Riding	83	85,86,87,88, 89,90
Working Hunter Over Fences	67	70

## **CORPORATION BYLAWS**

### **ARTICLE I:**

#### **TITLE, OBJECTS, LOCATION. CORPORATE SEAL**

Section 1. Title: This Association shall be known as NATIONAL QUARTER PONY ASSOCIATION, (NQPA), and shall at all times be operated and conducted as a nonprofit association in accordance with the laws of the State of Ohio, providing for such organizations and by which it shall acquire all such rights as granted to associations of this kind.

Section 2. Objects: The purpose of NQPA shall be to collect, record and preserve the pedigrees of National Quarter Ponies, to maintain a Stud Book and registry, and to stimulate and regulate any and all other matters such as may pertain to the history, breeding, exhibition, publicity, sale or improvements of the breed.

Section 3. Place of Business: The principal place of business shall be Melrose, Paulding County, Ohio, but its members or officers may be residents of any state, territory or country, and business may be carried on at any place convenient to such members or officials, as may be participating.

Section 4. Corporate Seal: The seal of NQPA shall be in the charge of the Executive Secretary and shall be in the form impressed hereon immediately below.



## **ARTICLE II: MEMBERS**

Section 1. Members shall be admitted, retained and expelled in accordance with such rules and regulations as the Board of Directors may, from time to time, adopt. In all matters governed by the vote of the members, each member in good standing shall be entitled to one vote.

Section 2. The regular annual meeting of the members shall be held at such time and place as may be established by the Board of Directors. For the purpose of electing directors and for the transaction of such other business as may be brought before the meeting every (3) three years. Notice to members of any annual regular or special meeting of members will be made on the internet, and on the website, and no other notification shall be required. .

Section 3. Special Meetings of the members may be held at such time and place as may be designated in the notice whenever called in writing by direction of the President or by the majority of the Board of Directors, or by notice signed by not less than 20% percent of the members then in good standing.

Notice of each special meeting, indicating briefly the object or objects thereof, shall be given in the same manner as provided with respect to notice of annual meetings.

Section 4. At any meeting of the members, attendees at such meetings shall constitute a quorum, except as otherwise provided by the Statutes of the State of Ohio. To exercise voting privileges, a member must be physically present at a meeting, which privilege cannot be delegated by proxy.

**ARTICLE V-PLACE OF BUSINESS:**

SECTION 1: The place of business of this association shall be NQPA headquarters in Melrose, Paulding County Ohio

SECTION 2: All correspondence regarding NQPYA shall be directed to the Youth Activities Department of NQPA in Melrose, Ohio

**ARTICLE VI-AMENDMENTS**

The Constitution of the organization may be amended at the annual meeting of the Board of Delegates by a two-thirds vote of delegates present, provided a quorum of the delegates is in attendance .

**ARTICLE VII-TERMINATION OF MEMBERSHIP AND REMOVAL OF OFFICERS:**

Membership and election of officers in the NQPYA is a privilege , not a right, which may be terminated or refused for cause detrimental to the interest of NQPYA, of which it is a division, its programs, policies, objectives and harmonious relationship of its members. A member may be removed from the membership roll, an officer may be removed from office, a director may be removed from their position.

**ARTICLE III: DIRECTORS**

Section I. The business and property of NQPA shall be managed and controlled by the Board of Directors. The bylaws and rules affecting registration of ponies shall be subject to change only by the Board of Directors.

The number of Directors shall be 6 or such other number not less than three, as may be fixed by the members from time to time at the annual meeting or other meeting held for the election of Directors. Elected Directors shall hold office for a period of three years.

In addition to the Directors so elected, all present and future Past Presidents of NQPA shall be lifetime Directors-at-Large, with voting privileges.



**ARTICLE III: DIRECTORS Continued:**

In addition to Directors and Directors at Large, the Board of Directors shall contain a category of Director Emeritus, in recognition of the individual who merits special recognition for their efforts at the national level, in furtherance of the aims and objectives of NQPA.

The recipient must be worthy of the award and must be a supporter of the National Quarter Pony industry. Director Emeritus is an honorary title awarded only by nomination and majority vote of the Board of Directors. Director Emeritus is a lifetime position and carries lifetime membership.

Members of the Board of Directors shall receive no pay for their services, but shall receive benefits of NQPA commensurate with the duties and responsibilities which may be approved from time to time.

Directors shall be reimbursed for itemized expenditures incurred in the organization of NQPA verified to and approved by the Board of Directors.

A Director may be removed from office for conduct unbecoming of the position and /or for failure to **Attend a Minimum of Three Board Meetings each year**. A majority vote of Directors present is needed to remove a Director.

In case of any vacancy in the board of Directors by death, resignation, disqualification, increase in number or other cause, the President, with the advice and consent of the board of Directors, shall appoint a qualified successor to serve until the next general election of Directors at an annual meeting of members.

Section 2.

The regular annual meeting of the Board of Directors shall be held immediately following the annual member's meeting, and no notice shall be required for any such regular meeting of the Board.

**ARTICLE III: DIRECTORS Continued:**

The Board, by rule, may provide for other regular meetings at stated times and places, of which no notice shall be required, for the purpose of transacting business as may be necessary. At the regular annual meeting of the Board of Directors, the Board shall elect officers of NQPA. At all such meetings of the Board, majority of the number of Directors shall constitute a quorum.

Section 3. The Board of Directors shall have the power and authority to make, amend, repeal and enforce such rules and regulations, not contrary to law or the Certificate of Incorporation or these Bylaws, as they may deem expedient concerning the conduct, management and activities of NQPA, the admission, classification, qualification, suspension and expulsion of members, removal of officers, the rules and regulations governing the procedure of such suspension and expulsion and removal, the fixing and collecting of dues and fees, regulations regarding maintaining the stud book, registration, expenditures of money, auditing of books and records, awarding of championships, conducting of shows, contests, exhibitions, sales and social functions and other details relating to the general purposes of NQPA, all, however, subject to revision or amendment by the members at any regular or special meeting of the members, provided written notice of intention of any rule or regulation shall have been mailed to all members at least 30 days in advance of the meeting.

#### **ARTICLE IV: OFFICERS AND DUTIES**

Section 1. The Officers of NQPA Shall be the President, Vice-President, Treasurer, Secretary, Points Secretary, and Web Officer of whom shall be Directors. Said Officers shall be elected by the Board of Directors by majority vote, and shall hold office for the period of three years and until their successors are elected and qualified.

Section 2. President: The President shall be the chief executive officer of NQPA and shall preside at all meetings of the members and Directors. He / She shall see that the Bylaws, rules and regulations are enforced, and shall perform all other duties that may be prescribed from time to time by the Board of Directors. He shall be ex officio member of all committees.

Section 3. Vice-president. In the absence of the President the Vice-President shall have the powers and perform the duties of the President and other such duties as may be prescribed by the Board of Directors.

Section 4. Treasurer shall receive and have in charge all money and securities belonging to the Corporation, and shall disburse same only upon itemized demands and upon the order of the Board of Directors. He shall provide an accurate account of all money received, disbursed and on hand, and shall generally perform such duties as may be required of him by the Directors. On the expiration of his term of office, he shall forfeit to his successor or to the Board of Directors, all money and properties of NQPA in his possession.

#### **ARTICLE IV: OFFICERS AND DUTIES (continued)**

Section 5. Secretary. The Secretary shall keep minutes of all meetings of the members and Board of Directors, and make a proper record of same, which shall be attested by him. The Secretary shall answer correspondence, record registrations and transfers in stud book, perform the duties of editor of the NQPA News journal, report activities to the Board of Directors, and generally perform such duties as shall be required of him by the Board of Directors.

Section 6. Points Secretary. There shall be two points secretaries to keep track of all points earned by members and ponies, to ensure accuracy of point tabulations.

Section 7. Web Officers. There shall be two web officers to keep the official website of the group updated with current events, notifications of all regular and special meetings, and of any rule changes. The officers are required to update the website at least one time per month thru out the year.

#### **ARTICLE V: AMENDMENTS**

The Board of Directors shall have the power to make, amend and repeal the Bylaws of NQPA by vote of the majority of the Directors at any regular or special meeting of the Board, subject to the right of the members to rescind or amend any such Bylaws in the same manner as provided in Article III, Section 3, for the revision or the amendment of rules and regulations.

#### **ARTICLE VI: INDEMNIFICATION**

The Corporation shall indemnify and hold harmless each Officer, Director and employee of NQPA, their personal representatives and heirs, against reasonable legal expense, judgments, and expense of settlement which NQPA previously approved, actually and reasonably incurred in connection with an actual or threatened legal proceeding, if such person acted legally, in good faith, and was duly authorized to act on behalf of NQPA in the transaction from which legal liability arose, which was official NQPA business, except in relation to matters as to which he shall have been guilty of negligence or misconduct in respect of the matter in which indemnity is sought. To preserve this right of indemnity, such person shall immediately notify NQPA of such actual or threatened litigation, whereupon NQPA shall have the right to direct defense thereof, including, but not limited to, selection of counsel, and direction of settlement negotiations.

#### **ARTICLE VII: ORDER OF BUSINESS**

Unless this regulation is suspended by a majority vote of the members present at any meeting of the members, the order of business at all members meetings shall follow Roberts Rules of Order. Director; position or an individual may be refused membership by the Advisory Board after prior written notice of the time and place of hearing, containing specification of charges, where the individual may attend, with counsel, to hear evidence against him, and present evidence on his Behalf. The ruling or action of the Advisory Board may be appealed to the NQPA Executive Committee by written request filed with the Executive Vice President within 15 days of the ruling date, which appeal shall, however, not suspend the effect of the ruling

**SECTION I.  
GENERAL RULES AND REGULATIONS**

**1. MEMBERSHIP:**

A. Membership in NQPA is a privilege, not a right, application for which shall be made on forms and by fees and procedures prescribed from time to time by NQPA. Membership, or application therefore, may be terminated or rejected by the Board of Directors for cause detrimental to the interest of NQPA, its programs, policies, objectives and harmonious relationship of its members as determined by the Board. Termination or application rejection proceedings under this rule shall be conducted under NQPA's disciplinary procedures. The effect of termination or rejection may be denial of the privileges of NQPA as set forth in NQPA disciplinary procedures.

B. The record owner and each exhibitor shall be current NQPA members for points to be earned in NQPA approved or recognized Shows.

1. Each year, the record owner and each exhibitor shall receive a total tally amount of points. If any, earned throughout the year.

C. General privileges and responsibilities of members and nonmembers are as follows:

1. While in good standing, all members have equal rights, interests and responsibilities with respect to NQPA and its property; shall obey and be bound by all Bylaws, rules and regulations of NQPA and decisions or actions of the Board of Directors; have the right to vote by personal attendance at membership meetings; and have the right to hold office and committee assignments, except as otherwise limited.

Membership in good standing" means an individual or other legal entity who has paid the requisite membership fee; is not under current suspension by the Board of Directors; or does not owe a delinquent financial obligation to NQPA for fees or other account payable for which written notice of suspension of membership or participation privileges has been sent.

**MEMBERSHIP CONTINUED :**

2. Individuals who are non-members, but own National Quarter Ponies, file registration applications and other documents with NQPA or participate in NQPA approved events, by such actions and in regard to such transactions, do thereby agree to be bound by all Bylaws, rules and regulations of NQPA and decisions and actions of the Board of Directors.

3. Every member, by joining NQPA, or non-member, by purchasing National Quarter Ponies, filing registration applications or other documents with NQPA or participating in NQPA approved events, does thereby agree:

a. If unsuccessful in an attempt to overturn NQPA decisions, actions, rules or regulations, to reimburse NQPA for its reasonable attorney's fees, court costs and other expenses in defense of such suit.

b. That he will not commence any action, whether in law or equity, against NQPA in any courts other than those Federal and State courts located in Paulding County, Ohio.

4. As reciprocal assistance to NQPA for privilege of membership, participation in approved event and ownership of a National Quarter Pony, NQPA may use any photograph or other form of likeness reproductions of a member, event participant, pony owner, or their ponies, to promote NQPA's objectives and active ties including, but not limited to, use by third parties with authorization from NQPA.

• **NQPA MEMBERSHIP**

• The following designations of membership in NQPA are available, entitling the recipient to the designated period of eligibility, which is January to December 31st upon application, qualification, and payment of the requisite fee, which carries the indicated and payment of the requisite fee, which carries the indicated membership privileges:

1. Individual annual membership is restricted to one individual person, including one vote. An annual membership is not transferable.

2. Youth annual membership is restricted to one individual person, who is 18 years of age or under, all the usual privileges of membership. A youth membership does not have voting rights

### **MEMBERSHIP CONTINUED :**

3. Family annual membership entitles two individual adults and minor children of one household to all usual privileges of membership, in lieu of individual annual memberships, including two votes.

4. Life membership is restricted to one individual person, entitling recipient to all usual privileges of membership, without annual dues. A life membership is not transferable.

### **2. VIOLATIONS:**

A. No person shall treat any horse or pony in a cruel or inhumane manner. Cruelty to horses, other than National Quarter Ponies is included in this prohibition, as it indicates a general course of dealing with horses, which is unacceptable for NQPA membership qualification. For violation of this rule, an NQPA member may be disciplined, suspended, fined and/or expelled from NQPA, and a nonmember may be denied NQPA privileges. This prohibition against cruelty includes, but is not limited to, NQPA members and/or owners of National Quarter Ponies, their agents, representatives, and employees, the actions for which a member or owner are also responsible.

B. Ownership of an issued registration certificate remains with NQPA; is issued in reliance on a written application submitted and attested by the applicant; and upon the express condition that NQPA has the privilege to correct and/or cancel the certificate for cause under its rules and regulations. No person shall refuse an NQPA request for the return of a registration certificate, either before, after or pending hearing to determine registration or participation privilege in NQPA approved events. NQPA may retain possession of a certificate until resolution of the matter for which the return of the certificate was requested.

C. In the furtherance of their official duties, all NQPA representatives shall be treated with courtesy, cooperation and respect, and no person shall direct abusive or threatening conduct toward them.



## **2 VIOLATIONS CONTINUED:**

D. Any member may be expelled, suspended or denied privileges of NQPA, and any nonmember may be denied privileges of NQPA, for failure to pay when due any obligation owed to NQPA, or for giving a worthless check for registration, transfer, show entry fees or any other fees or charges including bank charges for returned checks connected with the exhibition of ponies; Or for failure to timely file with NQPA any report required by the rules of NQPA; provided that 15 days before action by the Board of Directors, written notice of the account due or delinquent report and the Intention to suspend or withhold privileges shall be mailed to each member or non-member. Upon suspension by the Board of Directors, the name of the member or nonmember may be published in the NQPA News Journal, beginning with the next available issue from date of suspension. Any suspension and denial of privileges under this section shall terminate upon full payment of the obligation due NQPA or filing of the requisite report.

E. Registrations and memberships may be collected at the shows, Unless inspected at Approved shows all memberships and registrations must be sent by mail.

## **3. DISCIPLINARY PROCEDURE:**

A. Anyone accused of any violation, shall be given not less than 15 days notice of a time and place for hearing such accusation by the Board of Directors at which he shall have the opportunity, in person, and by counsel to present evidence in his own behalf and to hear and refute evidence against him. Such notice is deemed received when, delivered according to NQPA's general notice procedure.

B. Every notice required by these rules and regulations may be served by delivering the notice to the person to be served or his attorney, either in person or by mail postage prepaid, to his last known address as it appears on NQPA's records; and upon mailing, such notice shall be deemed received by such person when it is deposited in the United States mail

#### **4. GENERAL NOTICE PROCEDURE:**

Every notice required by these rules and regulations may be served by delivering the notice to the person to be served, or his attorney, either in person or by mail postage prepaid, to his last known address as it appears of NQPA's records; and upon mailing, such notice shall be deemed received by such person when it is deposited in the United States mail.

#### **5. INSPECTORS:**

A. Inspectors shall be appointed by the Board of Directors, and must hold current NQPA membership.

B. Not more than five (5) inspectors will be appointed from each state.

C. Inspectors shall possess a thorough knowledge of NQPA Rules and Regulations. He/she shall have a complete understanding of the Quarter Pony type standard as it relates to conformation, height limitation, and general appearance

D. Inspectors shall inspect and measure ponies for the purpose of registration in the NQPA. Three inspector signatures are required on all NQPA temporary or permanent height cards.

E. Inspectors shall not collect membership fees or registration fees or applications, but shall instruct owners to send forms and fees to NQPA. Directors shall not charge owners for any inspection services, but may be reimbursed by NQPA for excessive travel expenses.

F. Board of Directors shall retain the right to review, and/or suspend Inspectors who are not complying with the qualifications outlined above.

G. All Officers of State Charter clubs and organizations shall be State Inspectors.

H. All NQPA Directors shall be National Inspectors having the authority to inspect ponies in all states.

I. No Inspector shall measure a pony they own or lease, nor shall they inspect any pony owned or leased by a member of their immediate family

## **6. SHOW STEWARDS:**

- A. A competent show steward shall be required at all approved NQPA shows. The show steward shall be a Officer, Director, or inspector of NQPA, and shall be familiar with NQPA rules.
- B. The show steward shall assure that NQPA rules and regulations are adhered to, handle protests, manage disputes and generally oversee show management judge and exhibitor behavior and report incidents to NQPA.

## **7. JUDGES:**

A. Designation as an NQPA approved judge is a privilege, not a right, bestowed by the Board of Directors to individuals whose equine expertise and personal character merit the honor. An individual's conduct as a member, exhibitor and judge, and ability must be exemplary; is subject to continual Board of Directors review; and such designation is revocable with or without notice and a formal hearing.

### **B. JUDGES SHALL:**

- 1. During an approved show, be present to meet his/her responsibilities under NQPA rules, and shall be available to assist show management in meeting its responsibilities of rule compliance.
- 2. Wear western attire, including hat and boots while judging an approved show.
- 3. At all times, act in a professional manner.

### **C. JUDGES SHOULD:**

- 1. Place a pony in whatever position the merit of the pony justifies. The judge's decision shall be final in all cases affecting the merits of the ponies.
- 2. Order any person or pony from the competition for poor conduct of either and may disqualify any contestant for excessive abuse of the pony.
- 3. At his/her discretion, refuse entry into the arena or remove an entry from a class for improper attire and/or equipment and/or lame animals.

**D. JUDGES SHALL NOT:**

1. Have a conflict of interest between NQPA's objective and their own personal business interests. Each judge should refrain from using his or her official status to further one's own personal or financial purpose. When such conflict of interests arises, the judge is expected to either withdraw the personal objective from the transaction in question or resign from NQPA'S approved judges list, so he / she may pursue the personal objective. Breach of this ethical rule shall be subject to review according to NQPA rules. Certain specific areas of obvious conflict of interest for judges are as follows:

A. Judge a pony which is owned or exhibited by anyone from whom he / she has received a salary, commission or any kind of remuneration for selling or buying any pony for that individual, whether or not a pony is concerned in the transaction, has been in the employ, or has represented such individual in any capacity for remuneration within six months from the date of the subject show.

B. Judge a pony belonging to, or being exhibited by, any member of his immediate family (son, daughter, father, mother, sister, brother). If a judge cannot exercise an objective opinion, free from possible prejudice, bias, or outside influence, because of a connection with an owner, exhibitor or anyone else connected with the pony, or, for that matter, if such connection would appear to others of possible bias, whether or not the judge feels he or she would be affected, a judge must disqualify himself or herself.

C. Visit the stall area, nor visit with owners, trainers, exhibitors, or owners' representatives, nor inspect or discuss any pony entered in the show before the judging, including the day prior to the contest.

D. Once a class has been judged, it shall not be rejudged, and once the judge has marked his or her card and places for awards made, there shall be no changing of the judge's record.

## **7. Judges continued;**

E. Removal from the list of approved judges for any reason shall be absolute, with no provision for automatic reinstatement. Upon regaining eligibility for approved judging credentials, the individual shall apply for reinstatement after the expiration of one year from the date of qualification under the current procedures for admission of new applicants.

F. After the judge has accepted a judging assignment, exhibitors shall not contact, nor attempt to contact the judge pertaining to judging of any ponies at that show. Further, exhibitors shall not approach judges for any reason prior to the completion of judging unless the ring steward is present.

G. Any request to speak to the judge must be made through the ring steward.

H. No exhibitor will visit or socialize with a judge the day Prior to or day of the show.

I. When an exhibitor makes a request through the ring steward or other show official for the judge's opinion concerning that exhibitor's pony, it is urged that the judge will give his/her opinion courteously and sincerely in the presence of the ring steward or other show official; however, there will be no fraternization between an exhibitor and judge during the show.

J. An NQPA approved judge shall be treated with courtesy, cooperation and respect. No person, exhibitor, owner, or other wise shall direct abuse or threatening conduct toward them, either in the furtherance of their judging duties, or as a result thereof, whether or not the conduct occurs during an approved event or show, or on show grounds.

## **8. STATE CHARTERS:**

A. All state, province, regional and foreign NQPA Clubs shall be incorporated as nonprofit corporations in accordance with the laws of their respective states, provinces or countries and under the parentage of NQPA .They must adhere to the purpose and rules of NQPA and be subject to the approval of the Board of Directors.

B. There shall be no more than one state club in each state, or one province club in each province, or one regional club in each region nor shall there be duplicated foreign clubs in any area; provided, however the Board of Directors can approve an additional state or province Club or club crossing state or province lines if the majority of the Board of Directors finds that it will better serve and promote the overall NQPA organization.

C. To form a new club, the new club must send to the Board of Directors the request for a new club application, the proposed bylaws, and the proposed articles of incorporation as a nonprofit club according to the laws of their state. They must also send a list of the new officers and members plus a short summary of what their club plans to do to better the NQPA organization.

D. The Board of Directors shall put the issue on the agenda of the next official Board Meeting for the Directors' vote.

E. The State Charter fee is an annual fee payable to NQPA

F. The cost of Annual Insurance and Website will be Equally divided between all Charters.

**9. CONSTITUTION OF THE NATIONAL  
QUARTER PONY YOUTH ASSOCIATION  
ARTICLE 1-NAME AND PURPOSE**

Section 1: This organization shall be a division of the National Quarter Pony Association, shall operate within the scope of the bylaws, rules and regulations of the NQPA, and shall be named the National Quarter Pony Youth Association.

Section 2: The objectives and purposes of the National Quarter Pony Youth Association, hereafter referred to NQPYA , shall be as follows: a. To improve and promote the National Quarter Pony breed. B. To improve and develop the capabilities of youth c. To develop and improve scholarship , leadership, and community interest and participation of young horseman d. To encourage high moral character, sportsmanship and clean living among all its members e. To establish a means whereby youth members may work in conjunction with NQPA Youth Activities Committee. f. To create, foster, and assist subsidiary youth affiliates with the parent organization, NQPA, its structure and functions.

Section 3: The NQPYA Motto

**ARTICLE II-Membership NQPYA**

Section 1: Classes of membership: This organization shall have the following classes of members: A. Organizational Members, consisting of youth affiliates. The designation youth affiliate shall be defined as one youth association per state/province or international affiliate, acceptable to and approved by NQPYA and its Advisory Board. B. Individual members, consisting of boys and girls 12 to 18 years of age. C. Voting rights in the organization shall be vested exclusively in organizational members, each of which shall be entitled to designate four delegates for each youth affiliate. D, Annual fees are outlined in parent organization, NQPA fee schedule. NQPYA will additionally have annual dues of \$3.00, which membership shall allow a youth all privileges of a regular member, and in addition, all privileges of a member of NQPA, the parent organization, except the right to vote at the NQPA membership meetings , and hold office in parent organization

**NQPYA continued:**

The monies of the organization shall be deposited in such manner, in such banks, or trust companies, and may be withdrawn in such manner as the Board of Delegates and Advisory Board may Direct or designate. Furthermore, this organization reserves the right to additional financial policies/procedures in place to ensure accountability/transparency of its financial records.

**B. ARTICLE III—NQPYA OFFICERS, DELEGATES, DIRECTORS AND EXECUTIVE COMMITTEE**

SECTION 1: The business and property of the organization shall be managed and controlled by the Board of Delegates and an Executive Committee hereinafter created and empowered.

SECTION 2: Delegates: A youth affiliate shall exercise its voting privileges in the organization through its delegates, annually elected by the resident members in good standing of each youth affiliate. A. Vacancy : In case of any vacancy in the Affiliate Board of Delegates, the President of the youth affiliate shall appoint a successor to fill the unexpired term of the affiliate's delegate. B. Meetings : The regular annual meetings of the Board of Delegates shall be held at such time and place they may be fixed by the NQPYA Executive Committee for the purpose of electing, Officers of the organization and for the purpose of such other business as may be brought before the meeting. Special meetings of the Board of Delegates may be held at such time and place as may be designated in the notice, whenever called in writing by the direction of the President or by majority of the Board of Delegates.

C. Notice of meetings: Written or printed notice of all meetings stating the place, date and hour of the meeting, and in the place of a special meeting, the purpose or purposes of which this meeting is being called, shall be delivered not less than 15 days before the date of the meeting, either in person or by mail, at the discretion of the president or secretary, or the officer or person calling the meeting, to each recognized youth affiliate entitled to vote at such meeting. If mailed, such notice be deemed to be delivered, upon deposit in the United .



**NQPYA continued:**

States mail addressed to recognized youth affiliates at their address as it appears on the records of the association, with postage thereon prepaid

D. Quorum: A majority of the number of delegates shall constitute a quorum for the transaction of business, but if at any meeting of the board there maybe less than a quorum present, a majority of those present may adjourn the meeting from time to time until a quorum shall be present.

E. Powers of the Board: The Board of Directors shall have the power and authority to direct affairs of the organization, including, but not limited to, the right to make, amend and repeal the constitution of the organization , as they may deem expedient concerning the conduct, management and activities of the organization, the admission classification, qualification, suspension and expulsion of members, removal of officers, expenditures of money and other details relating to the general purposes of the organization, subject to the approval of the Advisory Board.

**SECTION 3: NQPYA OFFICERS:** The officers of the organization shall be the President, Vice President , Secretary, Treasurer, Sentinel, and Reporting Officer who shall be elected from and by the Board of Directors previously selected by the various regions in the organization. Such officers shall hold their office for a period of one year and until their successors are elected and qualified. An officer must remain eligible for NQPYA membership and a member in good standing for the duration of their term. ( An officer can not turn 19 before December 31 during the term in which they are serving.)

**.NQPYA continued:**

**SECTION 4: NQPYA OFFICERS;** A. President: The President shall be chief executive officer of the association and shall have general supervision of the affairs of the association, subject to the Board of Delegates, and shall preside at all meetings of the members and the Board of Delegates. The President shall appoint all committees of the association subject to approval of the NQPA and NQPYA Executive Committee. The President shall submit to the members annually at their meeting a report of the status of the association and its activities during the preceding year. The President shall have such other and further duties and authority as may be prescribed elsewhere in this constitution or from time to time by the Board of Directors. B Vice President; The Vice President shall, in the absence, disability or inability to act, of the President, perform the duties and exercise the powers of the President, and shall perform other duties as the B. VICE PRESIDENT ;

President shall prescribe from time to time. The Vice President will also serve as the Executive Committee regional representative of the region (s) which he/she was elected.

C. SECRETARY: The Secretary shall attend all meetings of the members and the Board of Delegates, and shall record or cause to be recorded all votes taken and minutes of all the proceedings in a minute book of the NQPYA to be kept for that purpose. He or she shall perform like duties for the committees when requested to do so. The Secretary shall have the principal responsibility to give or cause to be given notice of all meetings of the Board of Directors and the members, but this shall not lessen the authority of others to give such notice as provided in the Constitution .

**SECTION 4: OFFICERS continued :**

D. TREASURER: The Treasurer shall have the responsibility of examining the financial need of specific projects and needs of NQPYA, and reporting those costs to the Board of Directors. He or she shall be made aware of the continuing status of membership growth and corresponding payment of dues.

E. SENTINEL: The Sentinel shall have the responsibility of maintaining order at all meetings of the Executive Committee and the Board of Delegates in accordance with parliamentary procedure, in addition to preparing meeting rooms and facilities for the meetings of the Executive Committee and the Board of Directors. The Sentinel may also be required to fill those duties that may time to time be prescribed by the President. The Sentinel will also be responsible for compiling an annual scrapbook for NQPYA.

F. REPORTING OFFICER: The reporting officer shall have the responsibility of sharing news and notices with the NQPA Reporting Officer of the parent organization, NQPA. The Reporting Officer may also be required to fill those duties that may time to time be prescribed by the Board of Directors.

G. NQPYA DIRECTOR: Annually three (3) Directors shall be elected by the delegates of each designated region at a regular annual meeting of the delegates. The duties of an NQPYA Director are to enhance communication and serve as liaison between NQPYA membership and the Executive Committee. The candidate must also remain eligible for NQPYA membership and a member in good standing. For the duration of their term ( A youth director can not turn 19 before December 31 during the term in which they are serving )

**NQPYA DIRECTORS ; continued**

H. VACANCIES OF ELECTIVE OFFICES: All vacancies in the elective offices of the organization shall be filled by the Executive Committee from the Board of Directors for the unexpired term, and those so appointed shall serve until the election and acceptance of their duly qualified successors.

**SECTION 5 EXECUTIVE COMMITTEE:**

The NQPYA Executive Committee shall consist of the President, Vice President, Secretary, Treasurer, Sentinel, and Reporting Officer, elected by the Board of Directors at its annual meeting.

A. MEETINGS OF THE NQPYA Executive Committee The NQPYA Executive Committee shall meet whenever and wherever called by direction of the president or three members of the committee acting jointly, of which meeting the secretary shall give 10 days written notice, but such notice may be waived by any member.

B. POWERS of the NQPYA Executive Committee: All powers of the Board of Delegates are hereby vested in the NQPYA Executive Committee.

C. QUORUM: The quorum of the NQPYA Executive Committee shall be three (3) members.

D. During the interim between annual meetings, or special meetings, of the Board of Delegates,, the NQPYA Executive Committee is empowered to direct the affairs of the organization.

**ARTICLE IV : ADVISORY BOARD**

The Advisory Board of the organization shall consist of the NQPA President, the NQPA Executive Vice President, and any additional members appointed by the NQPA Executive Committee. The Advisory Board shall consist of at least four (4) adults to assist the NQPA Youth Activities Committee in directing the activities of the NQPYA. All actions of the organization and all nominees of the organization for election to the NQPYA Executive Committee shall be subject to the Advisory Boards approval.

## **10. NQPA SHOW PAYMENT POLICY**

A. For all exhibitors (NQPA/NQPYA) exhibitors Are expected to pay their bill in its entirety at the close of business on the last day of the show weekend .

B. Exhibitors whose bill is not paid by the close of business on the last day of the show will have a \$40.00 LATE FEE assessed.

1. For any bill left unpaid for thirty (30) days Or more, all points earned at that show will be forfeited. Failure to settle a bill, at the discretion of the Board of Directors, can result in suspension of membership

## **SECTION II. REGISTRATION RULES AND REGULATIONS**

### **11. STUD BOOK :**

The Official Stud Book of the National Quarter Pony Association shall consist of three classifications:

A. Permanent, which consist of ponies six years of age and over, in the following categories:

1. Stallions having permanent registration with the American Quarter Horse Association, eligible for breeding.

**As of January 2016, all stallions MUST HAVE a Genetic Panel Test performed and results sent to the NQPA mailing address**

2. Mares having permanent registration with American Quarter Horse Association, or having two registered AQHA parents, or having a registered AQHA sire and NQPA dam; eligible for breeding

3. Geldings

4. Spayed mares

B. Tentative, which consists of ponies under six years of age, which may be advanced to permanent upon meeting the necessary qualifications,

C. Hardship, consisting of mares classified as non-breeding stock which do not meet the pedigree requirements as set forth above. In the event that hardship mares produce offspring, those offspring may be considered for hardship registration on individual merit

**12. REGISTRATION CRITERIA:**

A. All ponies must measure no less than 46" and no more than 58".

1. Ponies shall be measured unshod, or if shod, 1/4 " May be deducted from the measured height to account for the shoe, or the shoe may be measured and the actual height of shoe may be deducted

2. All ponies applying for registration must be measured by (3) NQPA Directors or Licensed Veterinarian, and the measurement attested to on the registration application.

3. Measurement of NQPA registered ponies must be done by NQPA Directors at the beginning of each show season. That measurement should be recognized the entire show season

4. On January 1 of the year following the pony's fifth birthday (six-year-old year), ponies falling within the height requirements and meeting all other qualifications of the NQPA may be advanced to the permanent registry, and issued a permanent height card when measured by three (3) different inspectors.

4a. As of 1/2019, if a temporary pony( under 6 years of age) is not showing in the current year, the registered owner must send a current measurement by 3 Directors or a licensed veterinarian to maintain registration for that year. Failure to submit a current measurement by July 31 of that year shall result in revocation of the pony's registration papers

5. Ponies with a permanent height card should not require annual remeasurement unless protested. 6. Any pony over 5 years of age which measures more than 58" shall have its registration revoked.

B. Any pony meeting the height requirements 11.A. and holding a current registration with the American Quarter Horse Association (AQHA) shall be eligible for registration; they must meet all requirements, no excess white, ect. However, AQHA registration is not a requirement for Registration.

## 12. REGISTRATION CRITERIA CONTINUED:

C. The age of a pony shall be computed on the basis of a calendar year starting January 1 of the year foaled. It is a weanling during the calendar year foaled and a yearling during the first calendar year following its foaling date, regardless of the time of year foaled.

D. A gelding or spayed or hardship mare must have quarter type conformation for registration.

E. No animal shall be registered which exhibits any of the following characteristics: Pinto, Paint, Appaloosa, excessive white from the base of the ears to the corner of the mouth, excessive white above the top of the knee or hocks, or any gaited characteristics.

1. Ponies having white markings with underlying white skin beyond any one of the following described lines shall be ineligible for registration. a. A line parallel with the ground drawn around front leg at the point halfway between point of elbow and protrusion of the back of the knee.

b. A line parallel with the ground at the center of the gaskin in the hind legs; top point of reference to be bony protrusion at the inside of the stifle region and the most prominent protrusion at the top and inside of the hock.

c. A line around the pony's neck immediately behind the poll and through the midpoint of the throat latch

d. Within area as described as two inches on either side of venal midline; beginning at the point midway between the front legs and extending to and including the sheath or udder

e. Additionally, there is a single area of white markings underlying light skin, such that it can be completely covered with a disk one inch in diameter, either free-standing on a pony's body or being a portion of white markings extending past the above prescribed lines.

**12. REGISTRATION CONTINUED :**

1. Ponies applying for registration under NQPA Rule 12-A-3 or 4, 12-B or 12-C shall submit four (4) clear full view current photographs of the pony showing both sides, front and rear view, which clearly depict the conformation and/or characteristics of the pony.

2. If the NQPA Board of Directors deem that the confirmation or color of the animal is in question, additional photographs must be supplied upon demand.

G. In all instances, acceptance of the pony for registration rests with the NQPA Board of Directors. The Board of Directors may at its sole discretion may cancel a registration that no longer meets the requirements for registration.

**H. BREEDER REGISTRATION DISCOUNT**

Those individuals who register more than three (3) ponies a year will be given a Breeder's discount. The cost for the first three registrations will be \$25.00 each, and that each additional will be \$10.00 each.

**13. STALLION BREEDING REPORT:**

The owner, authorized agent or lessee of every National Quarter Pony stallion must make a written report showing the names, registration numbers and breeding date (s) of exposure of all registered National Quarter Pony, American Quarter Horse, and other pony mares exposed to said stallion since the previous November 30. Such report must be postmarked or delivered to NQPA on or before November 30 of the breeding year.

A. This report shall include all mares owned by the owner of the stallion as well as mares owned by other parties. The report shall be made on a form provided free of charge by NQPA.

B. Thirty (30) days must elapse between exposure to different stallions for foals to be eligible for Registration.

C. Foals which result from the breeding of an NQPA stallion, whose owner failed to report the breeding to NQPA on the required forms, will not be eligible for registration without penalty. Forms available upon request.



**14. BREEDER AND BREEDER'S CERTIFICATE:**

A. The breeder is the owner of the dam at the time of service, except when mare is held under lease at time of breeding, and written notification of such lease signed by the lessor is on file with NQPA at time of registration, in which event the lessee-breeder shall be named as breeder.

B. Those individuals wishing to prove lineage of unregistered ponies, may prove a Breeding Certificate, completed and signed by the record owner of the sire and the record owner of the dam at time of service. Breeder Certificates shall be required for any filly to be registered which is one year or younger.

**15. NAMING OF PONY:**

Each pony for which registration is applied must be given an acceptable name which does not conflict with the name of any other pony registered with NQPA. Either living or dead.

A. The name must not exceed 20 characters, including letters, numbers and blank spaces.

B. Punctuation marks, such as apostrophes or hyphens, are not permitted.

**16. TRANSFERS:**

A. Each transfer of ownership of a registered pony shall be recorded by NQPA. The last recorded owner shall deliver to the buyer the original Registration Certificate, together with a completed transfer report properly signed.

B. The buyer shall forward the completed transfer form, the registration certificate and the appropriate fee to NQPA for action. Transfer forms shall be made available at no charge by NQPA.

C. Transfer fee shall be \$10.00, nonmembers \$25.00.

### **17. LEASES:**

A. For a lease of a pony to be recognized by NQPA, written notice of such lease shall be filed with NQPA, signed by both lessor and lessee. The notice shall provide the effective date of lease and may provide a termination date. Otherwise it may be terminated by written notice giving termination date, signed by both lessor and lessee, or by a properly executed transfer report which shows a change of ownership from lessor to lessee, signed by the lessor. No additional fee shall be charged for termination whether automatic or by subsequent notice thereof.

B. The recording of a notice of lease authorizes a lessee to execute all documents pertaining to the recognized activities of breeding, showing or performance whether automatic or by subsequent notice thereof.

C. During the effective term of the lease, NQPA will not record subsequent changes in ownership until the lease is terminated. Only the lessee is authorized to sign a breeder's certificate, stallion breeding report or registration application pertaining to the lease ponies.

### **18. SURRENDER OF CERTIFICATE:**

A. In the event that a pony's height exceeds 58 inches or the pony shows visible signs of paint or Appaloosa characteristics or color, the registration papers shall be revoked, at which time the owner shall be required to surrender said certificate of registration to the Association.

B. When the owner of any registered animal disposes of that animal without papers or the animal dies, the owner shall notify the NQPA of the fact and surrender the appropriate registration certificate to the Association for proper notation. Canceled registration certificate will be returned to the owner, unless NQPA is otherwise directed.

**19. PROTESTS:**

- A. All protests must be made in writing and shall be signed by the party or parties making the protest.
- B. The \$100. requisite fee shall accompany the protest.
- C. If the protest is honored, one half of the fee is returned to the protesting party; one half of the fee is retained by NQPA for investigating the protest.
- D. If the protest is denied, the entire fee is retained by NQPA.

**20. FEES:**

Are payable in US funds only. The following fees shall be paid prior to the processing of requests for items or services listed:

Membership	Members	Non-Members
Individual Annual	\$15.00	\$15.00
Youth Annual	\$10.00	\$10.00
Family Annual	\$25.00	\$25.00
Individual Life	\$150.00	\$150.00
Youth Life (up to 19)		\$65.00

Registration:	Members	Non-members
Temporary (0-5 yrs)	\$25.00	\$40.00
Temp to Perm	\$15.00	\$25.00
Permanent (6& older)	\$35.00	\$50.00
Hardship Mares	\$50.00	\$65.00

Other Services:

Ownership Transfer	\$10.00	\$25.00
Reissue Certificate	\$5.00	\$10.00
Corrected Certificate	\$10.00	\$25.00
<b>Stallion to Gelding</b>	<b>\$10.00</b>	<b>\$25.00</b>

**If stallion is registered with NQPA and has been gelded, papers and funds need to be sent in to be updated and recorded**

Recording of Lease	\$5.00	\$20.00
Protest Fee	\$50.00	\$100.00
Charter Fee - Annual	\$25.00	\$25.00

Stallion Breeding Report Filing Fee:

	Members	Non-Members
Per Stallion	\$5.00	\$20.00
Per Mare	\$1.00	\$15.00
Penalty per foal	\$10.00	\$40.00

**SECTION III.  
RULES AND REGULATIONS**

**21. CONDUCT:**

The National Quarter Pony Association was founded to provide a place to show the Quarter Pony as an all-around family oriented recreational project. With this in mind, the NQPA requires that all owners and exhibitors display sportsman-like conduct and humane treatment of their ponies. Violations may result in disciplinary action up to and including suspension of NQPA membership.

**22. SHOW ELIGIBILITY:**

Owners or exhibitors currently on the list of suspended or disciplined persons will forfeit points which are earned while subject to disciplinary action.

A. Exhibitor

1. Every person competing in an NQPA approved class must possess a current NQPA membership card, or must complete a membership application and pay the appropriate fee at the show, which should be submitted with the show results.

2. **Only adults aged 19 years** or over may handle and/or exhibit stallions on the grounds of an NQPA approved show or event., weanlings and yearlings may be Stallions may not be exhibited in any youth class

3. Exhibitor age on January 1st. is maintained for the entire year.

B. Both owner or part-owners and exhibitors must be current members to earn points.

C. Pony

1. Points are awarded to permanently or tentatively registered stallions, mares, spayed mares and geldings

2. Proof of registration and measurement must be provided to Show Management when making entry at NQPA approved shows.

3. Pony name, registration number and name of owner will be required on entry forms. Ownership must be current.

4. All incorrect entries will forfeit their points from the particular show.

### 23. CLASS ROUTINE:

A. **Ponies must work both ways** of the ring at all required gaits. Ponies required to back should do so straight and easily, and stand quietly. The judge may ask for additional class gaits. Ponies required to back should do so straight and easily, and stand quietly. The judge may ask for additional tests from any pony.

B. Ponies should reverse to the inside, away from the rail. Ponies may be required to reverse at walk or trot only, and should not be asked to reverse at the extended trot, lope or hand gallop.

C. Entries should be penalized for being on wrong leads.

D. Excessive speed displaying lack of control should be penalized.

E. Trail, hunter over fences, and reining patterns should be posted at least one hour before class begins.

F. Showmanship, horsemanship and equitation patterns are determined by the judge.

G. Any class May be split by size of pony, age of pony, and or age of exhibitor at the discretion of the show committee.

H. Any class maybe split by size [56" and under, 56" and over) If there are {4} or more present at a show, of size, and or sex Division at the discretion of the show committee.

### 24. DISQUALIFICATION:

If a pony is disqualified, it is not to be placed, regardless of the number of ponies in the class, but counts as an entry in the class. Causes for disqualification includes:

A. **Failure by exhibitor to wear correct number (s)** in a visible manner.

B. Falling of pony or rider in any class.

C. Equipment failure which delays completion of the class; equipment which the judge determines to be unsafe, inhumane, or give unfair advantage.

#### **24. DISQUALIFICATION continued:**

D. Failure to follow exact course in trail, western riding, reining, hunter hack and contest classes.

E. Whipping or spurring the pony forward of the cinch.

F. Two hands or changing of hands on reins except as allowed.

G. Free hand used to support rider by touching any part of the saddle, except western riding, reining and contest.

H. Three refusals during fence work.

I. Lamé animals.

**J. Attaching child to saddle by any means**

#### **25. SHOW APPROVAL AND NOTIFICATION:**

A. Organizations or individuals desiring to hold an NQPA approved show must obtain NQPA approval; if show results are to be recorded by NQPA and points awarded to the ponies earning such. The minimum requirements for an NQPA approved show are listed below. The National Quarter Pony Association recommends more classes for better participation.

1. One halter class for mares.
2. One halter class for geldings.
3. One halter class for stallions.
4. One showmanship class.
5. One Western Pleasure.
6. One English Pleasure.
7. Reining and one additional western class(either trail or western riding, or ranch ).
8. Barrels and one additional contest class.

B. All current members should receive notification of NQPA approved shows 30 days before the show date.

C. Show results must be sent to NQPA no later than **15 days** following show.

D. Judges for NQPA approved shows. shall meet NQPA approval or shall have a current state 4-H judges card.

E. Shows denying or restricting entries will not be recognized

**25. SHOW APPROVAL AND NOTIFICATION continued:**

F. NQPA approved shows shall not be held within 100 miles of each show location on the same day.

1. In the two charter organizations

Or individuals schedule a show on the same day within 100 miles of each other, the following is how to be determined which charter/organization is allowed to hold show.

A. If the show date is to be used for NQPA Futurity, the date is contracted for that purpose, NO OTHER SHOW has precedence over the NQPA Futurities .

B. Whichever charter/organization submits request to NQPA for approval first will get the date approved. Requests for show date approval MUST be submitted, by email, USPS or at a NQPA Directors (1st) (first) organizational meeting of year.

**26. POINTS**

No class of less than two (2) ponies shall receive points, but all classes shall be judged. It is recommended that classes with less than two (2) entries be combined, in order that points may be earned and awarded.

Number of Ponies in class	1st	2nd	3rd	4th	5th	6th
2-3	.5					
4-6	1	.5				
7-9	2	1	.5			
10-12	3	2	1	.5		
13-15	4	3	2	1	.5	
16-20	5	4	3	2	1	.5
20 +	6	5	4	3	2	1

This is the normal class of 6 placings, at a NQPA, OQPA show, the Futurity class placings may go up to 10 places, and futurity paybacks go to 10

7th	.5
8th	
9th	
10th	

## **26. POINTS continued**

The Grand Champion of each sex division with entries in more than two (2) classes shall receive one (1) more point than the highest first place pony in the sex division.

The Reserve Grand Champion of each sex division shall receive one-half (1/2) point more than the highest first place pony in its sex division .

## **27. ATTIRE**

A. Optional Attire:

1. Western: chaps, spurs, gloves, protective head gear.
2. English: chaps, unrowelled spurs, gloves, protective head gear. Contest: spurs, protective head gear, shin guards, Long sleeve western type shirt required, preferably with collar .
4. English and Western Equitation: chaps at the judges discretion.

### **B Prohibited Attire :**

In all classes and events: Ball Caps or hats other than western or protective headgear.

## **28. OPTIONAL EQUIPMENT:**

- A. Western: breast strap, riata, or hobbles attached to saddle.
- B. English: crop, English breast plate, braiding of mane or tail.
- C. Contest: crops, bats or over and under gear, mechanical hackamore, tie downs, martingales, caves-son nose bands, protective leg wraps or boots, closed reins.
- D. Driving classes: hat, gloves, driving apron, or lap Robe.
- E. Fancy or expensive attire or silver on tack or other equipment shall not be given preference over clean working equipment.
- F. Chin straps and curb chains are permitted with a Minimum width of 1/2 inch, and must lie flat against the jaw, with no other materials used in conjunction.
- G. Fake tails as long as the tail is attached hair on hair, and not in a manner as to restrict natural tail Movement.
- H. Ranch Horse: Rules differ, please refer to; Rule #80

Page 85



## **29. PROHIBITED EQUIPMENT**

- A. Western, slip or gag bits, donut and flat polo mouthpieces, reining bits with one rein . Draw reins and tie downs ( except in contest events.)
- B. English; draw reins, tie downs, **standing martingales, (MAY BE USED IN WORKING HUNTER )** running martingales, figure eight or flash cavessons
- C. Boots, bandages or protective leg wraps of any type on the pony are prohibited, except in hunter hack, reining, western riding, and contesting classes

## **30. HALTER COMPETITION:**

A. All weanlings must have made application for registration to earn points.

B. NQPA Halter Points shall be awarded to tentatively or permanently registered ponies in the following classes:

1. Weanling fillies
2. Yearling fillies
3. Junior mares (5 years of age and younger)
4. Senior mares (6 years of age and older)
  - Mares 56" and under
  - Mares over 56"
5. Broodmares - Mares producing foal in current or previous year
6. Produce of Dam ( 3 foals normally held at Futurity)
7. Weanling colts
8. Yearling colts
9. Junior colts (5 years of age and younger)
10. Senior colts (6 years of age and older)
  - Stallions 56" and under
  - Stallions over 56"
11. Get of Sire
12. Yearling geldings
13. Junior geldings (5 years of age and younger)
14. Senior geldings (6 years of age and older)
  - Geldings 56" and under
  - Geldings over 56"

To be held at each Futurity Maturity show, Grand and Reserve of each sex, Stallion, Mares, and Geldings

### **31. PERFORMANCE CLASSES:**

The following events, divided into categories, have been approved for Register of Merit, NQPA Versatility, NQPA Champion and NQPA Superior (Event) Pony points:

- Category I.** NQPA HALTER
- Category II.** NQPA Barrel Racing  
NQPA Barrels and Cones  
NQPA Down and Back  
NQPA Flag Race  
NQPA Keyhole  
NQPA Poles  
NQPA Pylon Alley  
NQPA Speed & Control  
NQPA Speedball  
NQPA Stakes
- Category III** NQPA Ranch Horse Pleasure  
NQPA Ranchmanship  
NQPA Western Riding  
NQPA Reining  
NQPA Free Style Reining
- Category IV** NQPA Hunter Under Saddle  
NQPA Hunter Hack  
NQPA Working Hunter Over Fences
- Category V** NQPA Western Pleasure  
NQPA Walk Trot Trail  
NQPA Trail  
NQPA In Hand Trail  
NQPA Pleasure Driving
- \*Category VI** NQPA Western Showmanship at Halter  
NQPA English Showmanship  
NQPA Hunt Seat Equitation  
NQPA Western Horsemanship  
NQPA Lead Line  
NQPA Pee Wee Trail -Walk  
NQPA Walk & Trot Horsemanship  
NQPA Bareback Horsemanship  
NQPA Egg & Spoon  
NQPA Ground Roping  
NQPA Pee Wee Poles  
NQPA Pee Wee Barrels

\* Points apply to exhibitor Certificate of Achievement, Register Of Merit, Superior Awards, for annual and lifetime awards.

### **32. CERTIFICATE OF ACHIEVEMENT:**

A. A Certificate of Achievement is to establish a record of outstanding performance. There are two Certificate of Achievement- one for showman events and one for performance events.

B. A certificate of Achievement is awarded when:

1. **PERFORMANCE:** A pony must have earned at least 10 points in one or more performance events as outlined in Rule 30, Categories II through V. No pony can be advertised as Register of Merit in any specific performance class without having won at least five points in that specific event.

2. **SHOWMAN:** An Exhibitor must have earned at least 10 points in one or more events in Category VI. Points may be accumulated by exhibiting any NQPA registered Pony.

### **33. REGISTER OF MERIT:**

A. A Register of Merit is to establish a record of outstanding performance. There are Register of Merit for each individual event.

B. A Register of Merit is awarded when:

#### **1. HALTER:**

a. A pony must have earned at least 10 points in NQPA approved halter class.

b. A minimum of five halter points must be earned during or after the pony's two year old year.

2. **PERFORMANCE:** A pony must have earned at least 10 points in one performance event as outlined in Rule 29, Categories II through V.

3. **SHOWMAN:** Exhibitor must have earned at least 10 points in one class in Category VI.

**34. NQPA MEDALLION AWARD:**

A. The title Medallion Pony will be awarded to any pony which has earned 30 points in any one class in Categories I-V.

B. The title Medallion Exhibitor will be awarded to any one person which has earned 30 points in any one class in Category VI.

**35. HONOR ROLL:**

A. The title Honor Roll Pony will be awarded to any pony which has earned 5 or more Register of Merit in any classes in Category I-V.

B. The title Honor Roll Exhibitor will be awarded to any one person which has earned 5 or more Register of Merits in Category VI

**36. SUPERIOR EVENT AWARD:**

A. The title Superior Pony will be awarded to any pony which has earned 50 points in any one class in Categories I-V

1. In Halter, a minimum of 25 points must be earned during or after the pony's two ( 2) year old year

B. The title Superior Exhibitor will be awarded to any one exhibitor who has earned 50 points in any one class in Category VI

**37. NQPA BRONZE AWARD:**

A. The title Bronze Century Award Pony will be awarded to any one NQPA registered pony who has earned 100 points in Categories I-V, in any one class

B. The title Bronze Century Exhibitor will be awarded to any one exhibitor who has earned 100 points in any one class in Category VI

**38. NQPA SILVER AWARD:**

A. The title Silver Pony will be awarded to any pony which has earned 150 points in Categories I-V

B. The title Silver Exhibitor will be awarded to any one exhibitor who has earned 150 points in any one class in Category VI

**39. NQPA GOLD AWARD:**

A. The title Gold Pony will be awarded to any pony which has earned 300 points in any one class in Categories I-V

B. The title Gold Exhibitor will be awarded to any one exhibitor who has earned 300 points in any one class in Category VI

**40. NQPA PLATINUM AWARD:**

A. The title Platinum Pony will be awarded to any pony which has earned 500 points in any one class in Categories I-V

B. The title Platinum Exhibitor will be awarded to any one exhibitor who has earned 500 points in any one class in Category VI

**41. NATIONAL QUARTER PONY CHAMPION:**

The title NQPA Champion will be awarded by the Association to individuals ponies which have meet the following requirements:

A. Thirty points are to be earned for this award.

B. Points have been won in three or more shows under three or more judges.

C. A minimum of 15 points shall be earned in halter classes, with a minimum of 8 of these points being earned during or after the pony's two year old year.

D. A minimum of 15 points must be earned in Category II through V events, with only five points being earned in each of at least three Categories.

E. Each pony trying for NQPA Champion, Must Have 1/2 point in each Category; II-V (Rule C Already states said pony Must have 15 Halter points.

**42. NQPA SUPREME CHAMPION:**

A. The title NQPA Supreme Champion will be awarded by the Association to individual ponies that have earned a total of 5 superior event awards out of a minimum of 3 categories, excluding category VI.

**B. SUPREME SHOWMAN AWARD:**

The title NQPA Supreme Showman will be awarded by the Association to individual members that have earned a total Of 5 Superior event awards in Category VI

**43. NQPA HIGH POINT STALLION:**

The title High Point Stallion will be awarded to individual ponies that earned the most points in Stallion Halter during the current show season.

**44. NQPA HIGH POINT MARE:**

A. The title High Point Mare will be awarded by the Association to the individual pony that has earned the most points in Mare Halter during the current show season.

**45. NQPA HIGH POINT GELDING:**

A. The title High Point Gelding will be awarded by the Association to the individual pony that has earned the most points in Gelding Halter for the current show season.

**46. NQPA HIGH POINT HUNTER UNDER SADDLE:**

A. The title High Point Under Saddle will be awarded by the Association to the individual pony that has earned the most points in Hunter Under Saddle classes during the current show season

**47. NQPA HIGH POINT WESTERN PLEASURE:**

A. The title High Point Western Pleasure will be awarded by the Association to the individual pony that earns the most points in Western Pleasure during the current show season.

**48. NQPA HI POINT RANCH/RANCHMANSHIP**

A. The title of High Point Ranch and Ranchmanship shall be awarded to the individual pony who has earned the most NQPA points in all classes exhibited in , one pony one rider during the current show season

**49. NQPA HIGH POINT REINING:**

A. The title High Point Reining will be awarded by the Association to the individual pony who earns the most points in Reining for the current show season.

**50. NQPA HIGH POINT SHOWMAN:**

A. The title High Point Showman will be awarded to the individual exhibitor that has earned the most NQPA points in all classes exhibited in, on one pony, during the current show season.

**51. NQPA HIGH POINT CONTEST:**

A. The title High Point Contest Pony will be awarded by the Association to the individual pony that has earned the most NQPA contesting points in all contest events during the current show season.

**52. NQPA HIGH POINT OVERALL “NQPA PONY of the YEAR”**

A. The title Pony of the Year will be awarded to the pony That has earned the most NQPA points in ALL classes exhibited

**53. NQPA VERSATILITY AWARD PROGRAM AND  
ROY L. LYNAM MEMORIAL TRAVLING  
TROPHY**



A. The purpose of this competition is to demonstrate the versatile, athletic ability of the Quarter Pony.

B. This competition is the combination of four NQPA events: English Pleasure, Western Pleasure, Reining and Barrels Racing.

C. Conditions for entry: Pony must be registered with the NQPA. Both owner and exhibitor must be current members in the NQPA. A completed and signed nomination form (available from NQPA), accompanied by the nomination fee of \$25.00 must be received by the NQPA Versatility committee no later than May 1 of the entry year. Only the pony and exhibitor named on the nomination form may compete for points in the versatility event. A maximum of two exhibitor shall be permitted. Substitutions are not permitted without written consent of the Versatility Committee.

D. Compulsory events are the minimum number of NQPA versatility events in which nominated pony and exhibitor shall compete during the Versatility season (May 1 and October 1,) to be eligible to receive the Versatility Award.

Compulsory events are:

Three (3) NQPA English Pleasure

Three (3) NQPA Western Pleasure  
(size split class)

Three (3) NQPA Barrels

Three (3) NQPA Reining



**53. NQPA VERSATILITY AWARD CONTINUED:**

E. Points received in compulsory events shall be added to other NQPA Versatility Event points received during the Versatility season. These points shall be tabulated by the NQPA Point Secretary and forwarded to the Versatility Committee. The winner shall be the nominated pony and exhibitor accumulating the most Versatility points. **The most NQPA Barrel points will be used as a tie breaker.**

Only points in the classes listed in paragraph D will be counted as Versatility Event points. No other NQPA Pleasure points, Barrel points, Reining points, or Open points will be counted for the Versatility Award

F. Awards shall be: purse, (total of nomination fees plus added sponsorship money, less 10% administrative fees to NQPA), traveling trophy, plaque, added sponsorship awards, and ribbons to the first five placings. The awards shall be presented as follows:

1st Place: 40% of purse, traveling trophy, plaque, sponsor awards and Blue Ribbon.

2nd Place: 20% of purse, sponsor awards and red ribbon.

3rd Place: 15% of purse and yellow ribbon.

4th place: 10% of purse and white ribbon.

5th place: 5% of purse and pink ribbon.

**G. THE ROY L LYNAM MEMORIAL TRAVLING TROPHY.**

The traveling trophy will be presented to the Versatility Winner at the Annual Awards Banquet. The winner will keep the trophy in his/her possession until November 1 of the following year. The trophy shall be returned, in good condition, to the NQPA Versatility Committee no later than November 1. The trophy will be awarded permanently when the same pony and rider combination has won it 5 years in a row.

H. All rules, regulations, by laws of the NQPA shall apply to the Versatility competition.

**54. NQPA CONTESTING AWARD PROGRAM AND  
JAMES "GRANDPA RED" NIER  
MEMORIAL TRAVLING TROPHY:**

A. Awarded to the same pony and rider combination accumulating the most points

annually the following National Quarter

Pony Association, Inc. approved contest classes:

1. NQPA Barrels
2. NQPA Poles
3. NQPA Flags
4. NQPA Down 'N Back



**B. ELIGIBILITY:**

1. To be eligible for this award the same pony and rider combination shall compete in 3 minimum of each required approved classes listed above during the Show season in which the nomination was made.

2. The pony shall be registered with NQPA

3. The owner and rider shall be current members in good standing with NQPA.

4. Pony and rider combination shall be nominated no later that the start of the first NQPA approved show of the season.

5. A nomination form shall be completed and returned with nomination fee of \$25.00, to the NQPA no later then the first NQPA show of the nomination year.

C. The winner shall be the nominated pony and exhibitor accumulating the most points. In event of a tie, the composite Down & Back time will determine the winner.

**54. GRANDPA RED CONTESTING CONTINUED:**

D. Awards shall be: traveling trophy, certificate, and purse ( total of nomination fees plus any added sponsorship monies, less 10% administrative fees to NQPA)

To the first five placings. The Awards shall be presented as follows:

1st place: 30% of purse, traveling trophy, and certificate

2nd place: 25% of purse

3rd place : 20% of purse

4th place: 15% of purse.

5th place: 10% of purse.

From time-to- time as determined by relatives of James Nier (Award Administrators) and/or NQPA Board of Directors, additional prizes may be awarded.

**E. JAMES "GRANDPA RED" NIER MEMORIAL TRAVLING TROPHY**

The traveling trophy will be presented at the annual NQPA Banquet. The traveling trophy shall be the property of the winner for a period of one year. The traveling trophy shall be returned in good condition to the NQPA at the end of the one-year period or prior to the next Banquet, which ever comes first.

**55. NQPA ENGLISH PERFORMANCE AWARD  
AND "Supreme Champion #1 Guns Encore"  
MEMORIAL TRAVLING TROPHY**

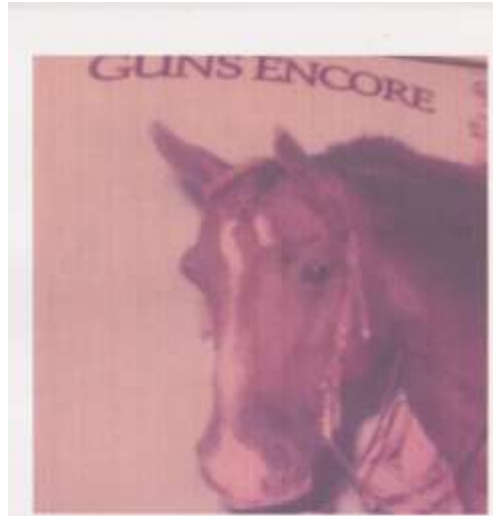

Awarded to the same pony and rider combination accumulating the most points in the following National Quarter Pony Association, Inc approved classes;

1. NQPA English Showmanship
2. NQPA Hunt Seat Equitation
3. NQPA Hunter Under Saddle
4. NQPA Hunter Hack

**ELIGIBILITY:** To be eligible for this award the same pony and rider combination shall compete in each class required for the award a minimum of 3 times ,points will accumulate each time the team shows in approved classes during the current show season in which nomination was made. The pony shall be registered with NQPA. The owner and rider shall be current NQPA members in good standing with NQPA. Pony and rider shall be nominated no later than the start of the first approved NQPA show of the season, or the first show the combination competes. A nomination form shall be completed and returned with nomination fee of \$25.00 to the NQPA address .

**55. NQPA ENGLISH PERFORMANCE CONTINUED:**

Filled out by exhibitors . 2 are allowed to show in this performance If there is a tie between participants The most Hunter Hack points will be used

AWARDS: A traveling trophy shall be awarded to the exhibitor accumulating the most English points in the above listed NQPA approved English classes. The traveling trophy will be presented at the annual NQPA Awards Banquet. The traveling trophy shall be the property of the winner for a period of one year. The traveling trophy shall be returned in good condition to the NQPA at the end of one year period or prior to the annual Awards Banquet, whichever comes first. In addition, a certificate to the winner, and a percentage of the purse will be awarded. The purse, less 10% administrative fee ( to be kept by NQPA), will be divided as outlined below and awarded to the first five (5) places. In event of a tie, the exhibitor that competed in the most classes will determine the winner. From time to time as determined by Val Anderson (Award Administrator) and or the board of Directors of NQPA, additional prizes may be awarded.

PURSE DISTRIBUTION (less 10% Administrative fee) First 30% second 25% third 20% fourth 15% fifth 10%

RULES: In addition to requirements previously outlined, all pertinent rules and regulations in the current NQPA Rule Book shall apply to this competition. Changes to the competition may be made at any time without prior notice by the Award Administrators and or the NQPA Board of Directors

**56. “TOP SHELF MEMORIAL FREE STYLE REINING”**

This class has been added to the National Quarter Pony Futurity/Maturity lineup. In memoriam for the NQPA stallion “Hes Top Shelf” that we lost too soon. He was a amazing reiner, and when he won the 2009 Free Style Reining class at Hilliard, Ohio; we knew he was a “good one”. He had many other awards thru his other reining endeavors, and has a few foals on the ground to continue his legacy.

A. Entry: Shall be at the current year NQPA Futurity/Maturity show, forms available any time in show season.

B. Entry Fee: Shall be \$20.00 with the payback and awards to be given at the current year NQPA Awards Banquet

C. Awards: Along with percentage payback from the entries, a revolving traveling trophy will be awarded to current year winner, to keep for one year or just prior to the current year Awards Banquet. Occasionally the presenter of this award, Bridget Hollern Heasley; owner of He’s Top Shelf may award other awards to the participants



### 57. "MGW BIT O CRÈME" MEMORIAL TRAIL CHALLENGE

This competition was created by Breeder Wendy Stephey and Owner Heather Echler to Honor a little yellow gelding, MGW Bit O Crème; {#3417-P} that held a place in our hearts. Who passed away too soon, only being 13. He excelled in many classes, but for owner's Heather & Tyler Echler; Trail class was one to better themselves every time out, and was close to being Supreme NQPA Champion #4. His sire was Master Gallant Wiz, NQPA Champion #16 and his Dam was Bit of Honey a hardship mare, who had a very good show record herself

So the 2 got together and decided to start a new competition class to be held during NQPA Futurity and OQPA Futurity show dates. Prior entry to Futurity weekends just as both Futurity weekend classes, with lots of new and fun obstacles to conquer. { As we all know Crème would be giggling at them if he could} IN the event of a tie, Judges scores will be used.

There will be a Traveling Trophy given out to the best of both Futurity class dates, and other prizes along with Futurity checks and or Cash; to the Top Ten, at the Current year, Year End Award Banquet.

National Quarter Pony Entry \$20.00 with 70% payback in the 2023 year end award Banquet

Ohio Quarter Pony Entry \$25.00 with 70% payback in the 2023 year end awards.



## **58. NQPA TUF N TUCKER MEMORIAL TRAVELING TRIAD AWARD**

ESTABLISHED IN 2019 and the program will run for 10 years

This award is to honor TUF N TUCKER aka "Johnny" P-3786 NQPA CHAMPION #43 who we lost too soon. He was well on his way to becoming the next Supreme Champion; who excelled in Halter, Hunter Under Saddle, and the Ranch classes. He was truly loved by many and a great pony and a great asset to our National Quarter Pony Association

### **ELIGIBILITY**

NQPA Registered geldings accumulating the most points in Halter, Hunter Under Saddle and Ranch Pleasure (Adult or Youth), at the end of the show season. At least two (2) points in each class; Total points for the year with the tie breaker to be Halter. This award will be for 10 years, the trophy will stay with the current year winner, then at the end of the 10 years the Trophy Award will reside with the owners Deb Hubbard Knight and Joe Knight.

The revolving trophy will be presented at each current Year End Award Banquet, and given to NQPA or family representative for the current year engraving before the Banquet.

No cost to members to enter this new traveling trophy but to keep accurate points please let show committee know if you are attempting to compete for this award.

Any questions regarding this award, please contact the Knight family or NQPA.





## **59. NQPA FUTURITY AND MATURITY:**

### **A. ELIGIBILITY**

1. Nomination of weanlings will be accepted from any state, province or country, provided that all owners and part owners are current member of NQPA

2. Foals shall be the offspring of registered NQPA, AQHA and/or AQHA parents

3. Weanlings shall be eligible for registration to earn points. To demonstrate eligibility, AQHA or NQPA parentage must be proven.

4. All ponies one year old or older shall have NQPA registration prior to exhibition in the Futurity.

5. All ponies which have been nominated to the Ohio or Indiana Futurity prior to 1996 are automatically eligible for this futurity without penalty.

B. All owners and exhibitors of ponies exhibiting at the futurity shall be members of the NQPA.

C. The NQPA Futurity shall consist of five divisions to be shown in 25 classes; or will be changed as seen fit

### **Futurity Division—Junior Ponies**

- a. Filly Halter Class
- b. Colt Halter Class
- c. Gelding Halter Class
- d. Hunter Under Saddle
- e. Western Pleasure
- f. Pleasure Driving
- g. Ranch Pleasure
- h. Ranchmanship
- i. Reining
- j. Barrel Racing
- k. In Hand Trail
- l Free Style Reining

### **Maturity Division—Senior Ponies**

- a. Mare Halter
- b. Stallion Halter
- c. Gelding Halter
- d. Hunter Under Saddle
- e. Western Pleasure
- f. Pleasure driving
- g. Ranch Pleasure
- h. Ranchmanship
- i. Reining
- j. In Hand Trail
- k Free Style Reining
- l. Barrel Racing

## **59. NQPA FUTURITY AND MATURITY continued**

D. Change of ownership will not affect the eligibility of a pony, provided the new owner is a member in good standing of the NQPA, and the Registration Certificate has been transferred to the new owner.

E. Entry fees are jackpotted and paid back to the winners in their classes according to the divisions listed below. 10% of the new purse will be used to defray expenses. Money is paid and ribbons are given to the top ten placings; however, all unearned place money, if less than ten ponies are shown, shall be prorated back to the places shown and earned.

F. The purses will be divided among 10 places in the following manner: 20%, 18%, 16%, 12%, 10%, 8%, 6%, 5%, 3%, 2%, for the futurity divisions.

G. Entry fees for the NQPA Halter and Performance Futurity less 10% administrative fee are deposited upon receipt into a separate account and are not combined with other funds of the NQPA. This account is not subject to any use other than the payment of awards in accordance with payoff rules for the events for which the fees were tendered by exhibitors. The following is the payment schedule. No fees for any Futurity / Maturity class (es) are due prior to the first show of the association each year.

### **1. Junior Futurity fees**

a. Class fee (per class) \$20.00

Payable by August

1. Halter
2. Hunter Under Saddle
3. Western Pleasure
4. Pleasure Driving
5. Ranch Pleasure
6. Ranchmanship
7. Reining
8. In Hand Trail
9. Barrels
10. Free Style Reining
11. MGW Bit O Crème Trail Challenge

## **59. NQPA FUTURITY AND MATURITY continued**

### **2. Maturity fees**

- a. Class Fee \$20.00 (per class)

Payable by August

1. Halter
2. Hunter Under Saddle
3. Pleasure Driving
4. Western Pleasure
- 5. Ranch Pleasure**
6. Ranchmanship
7. Reining
8. In Hand Trail
9. Free Style Reining
10. Barrel Racing
11. MGW Bit O Crème Trail Challenge

A pony may be nominated /reinstated in the futurity competition, including the maturity division, if the owner has missed a payment, a penalty fee of \$20.00 will be assessed. Late penalty payments are added to the appropriate divisions. The NQPA cannot be held responsible for entries which are not received in the office by their respective deadlines.

I. This program is administered by NQPA. All rules, regulations and Bylaws of the NQPA shall apply to the program. In addition to the eligibility requirements in paragraph A, ponies must meet maximum height requirements at various ages. The NQPA reserves the right to alter any fact of this program, provided all current NQPA members receive notification at least 30 days prior to deadline for first payment, per NQPA General Rule #4.

## **60. HALTER DIVISION:**

A. Halter Classes are judged on conformation.

B. Ponies may be exhibited in a western leather halter, hunter leather halter or bridle, or ranch horse halter [leather or rope].

C. Quarter ponies should have the following characteristics: The head should be proportionate to the body with clean cut features. The eye should be larger and prominent, the ears should be medium in size, alert, and well carried. A sloping shoulder and a prominent wither with fairly wide chest. The forelegs set well forward and should have a muscular forearm and a flat, short cannon bone. The feet should be rounded and proportionate to the size of the pony.

## **60. HALTER DIVISION continued:**

The body of the animal should be heavily muscled, with well sprung ribs and a deep heart girth. The hind quarters should be deep and muscular with well supporting hocks. The cannon bones in vertical line with point of buttock. Should have a prominent stifle and a well muscled, wide hind quarter. All parts should blend together in correct proportions to make up good balance, substance, ruggedness, quality and refinement.

## **61. TWO YEAR AND UNDER LONGE LINE:**

A. The longe line class is to reward the quality of movement and manners of the yearling pony. Although appropriate levels of training will be recognized, these ponies are not expected to demonstrate behavior or performance beyond that necessary for a reasonable presentation to the judge.

B. Equipment: Ponies are to be shown in a halter; a regular or show-type halter is acceptable. For the longeing demonstration, the only attachment allowed to the halter is the longe line. The longe line may not exceed 30 feet in length with a chain or a snap attached to the halter. The longe line must hang free from the halter without touching any part of the pony. A longe whip is permissible. No other equipment is allowed on the pony during the class. Mechanical or retractable longe lines are not allowed.

C. Attire: Needs to correspond to the type of pony; i.e., western for stock type or hunter for hunt type.

D. Gaits: To be judged according to the NQPA rules for the gaits for Western Pleasure classes and for Hunter Under Saddle classes.

E. Judging: Judge(s) will be outside the lunging circle. The exhibitor will enter the arena and await the audible start signal. When the signal is given, the exhibitor will be allowed 90 seconds to present the pony. At the end of the 90 seconds, the signal will be given

To signify the end of the run. Show management has the option of adding a 'half-way' signal, if they choose.

(The signal may be a bell, whistle, or announcement.)

F. The pony will be scored at all three gaits, walk, jog (trot), and lope (canter), in both directions. Any pony that does not exhibit these gaits in each direction will be disqualified from the class. Additionally, judges shall immediately excuse any pony who exhibits obvious lameness at any time during the class. The exhibitor may begin work in the direction of his/her choice (counter or clock-wise).

## **61. LONGE LINE CONTINUED:**

G. At the end of the 90 seconds, the signal will be given, and the exhibitor shall, at the request of the show management, either retire from the lunging area and line up at the end of the arena or leave the ring and wait nearby to be called back for conformation judging and placing. If the exhibitor stays in the arena, the pony should stand quietly while other ponies are being judged. For the conformation judging, the exhibitor may place a chain over or under the ponies nose, but this is allowed only for that portion of the class.

H. Judges should give a preliminary performance conformation score as the pony is performing. After judging the lunging competition, the ponies will be lined up for conformation judging. Judges may not discriminate for or against bulk, but rather look for a total picture, emphasizing balance and athletic capability. Judges should use this opportunity to review their preliminary score.

I. If a ponies nose, mouth, or jaw area shows signs of broken skin, rawness, or bleeding, the pony will be disqualified and eliminated from competition.

J. If the pony plays on the longe line, it shall not count against the pony. The pony should be judged as though the pleasure prospect was playing in the fields. Judges may, at their discretion, penalize the pony for excessive bucking or running off or displaying attitudes that are uncomplimentary to pleasure ponies, such as excessive ear pinning or tail wringing.

K. Exhibitors are encouraged to exhibit their pony making full use of a 25' radius circle, as they will be scored on this.

L. Ponies should be exhibited according to type as they would be in a showmanship class.

M. Scoring of the class will be as follows

(Movement will count for 80 points is the total score):

1. The walk = 0 to 4 points total with 2 being average.
  2. The jog (trot) = 16 points each direction of the circle with 8 being average.
  3. The lope (canter) = 20 points each direction of the circle with 10 being average.
  4. Manners, attitude, and trainability = 0 to 10 points with 5 being average.
  5. Use of circle = 0 to 3 points.
  6. Performance conformation = 20 points.
- N. The judge may break any ties at his/her discretion.

## **62. SHOWMANSHIP DIVISION:**

A. Showmanship classes are judged on fitting and grooming of pony, and on ability of the exhibitor to present the pony properly and to its best advantage.

**B. Exhibitors may show in either western equipment and attire (including western halter), hunter equipment and attire (including bridle), or ranch horse equipment and attire [including leather or rope halter], unless separate classes are offered. See the General Rules of the Western, English and Ranch Performance Divisions regarding attire and appointments.**

## **63. ENGLISH PERFORMANCE DIVISION:**

A. Exhibitor attire: Hunt hat (hard), blouse, hunt breeches, hunt boots, and hunt jacket. At the judge's discretion, wearing of jackets may be excused.

. English Equipment

1. An English snaffle (no shank), kimberwick, pelham and/or full bridle (with two reins), all with cavesson nosebands and brow bands must be used.

2. May have connecting bars or rings as per Western bits. Smooth round, slow twist, corkscrew, single twisted wire, double twisted wire, straight bar or solid mouthpieces with maximum 1 1/2" port height are permitted.

3. Bits of any style (pelham, snaffle, kimberwick) having mouthpieces with cathedrals, donuts, prongs, or other sharp material should be cause for elimination

4. Saddles must be black and or brown and of hunt, dressage, or forward seat type, and may have insert on skirt. Saddle pads must be a classic style and composition.

**64. EQUITATION DIVISION:**

A. Points follow the exhibitor. Type, conformation and quality of the pony is to have no bearing on judging. Manners and response to the exhibitor however, indicate the degree of training received by the pony and should be credited to the exhibitor.

B. Riders may be asked to change from any gait to any other gait or halt on command. All changes should be prompt, smooth and made through light and tactful use of aids.

C. The judge may call for individual tests.

D. Entries to be judged at a walk, trot and canter, both ways of the arena. Rider shall maintain contact with the pony's mouth.

E. In English equitation, the judge may ask for a sitting trot, extended trot, or hand gallop

**65. ENGLISH PLEASURE (HUNT SEAT):**

A. Ponies should be shown at flat-footed walk, posting trot and three beat canter, with light contact. Pony should cover ground in a long, low frame. The poll should be no lower than the withers, with the headset not behind the vertical. The judge may ask for extended trot or hand gallop.

B. The class should be judged on performance, apparent ability to give a good pleasure ride manners, condition and conformation of the pony.

**66. HUNTER HACK:**

A. Each pony shall have the opportunity for at least one practice jump, either in the arena or makeup Arena, before the class begins.

B. Style over jumps, even hunting pace, flat work and manners of the pony are judged. Judging begins when the exhibitor enters the arena.

C. Each pony should individually negotiate a course consisting of a minimum of two jumps. Jumps are to be set up to a maximum of 2' in height. Jumps are set at 12 foot Increments; 36, 48, or 60 feet. Ground poles shall be used in front of all fences.

1. Jumps may be either cross rails or verticals

D. Ponies shall be shown at walk, trot, and canter both ways of arena, with light contact.

E. Ponies may be required to extend the trot and hand gallop. At the discretion of the judge, exhibitors may be asked to hand gallop, pull up, and stand Quietly after the last jump.



66. HUNTER HACK PATTERN #1

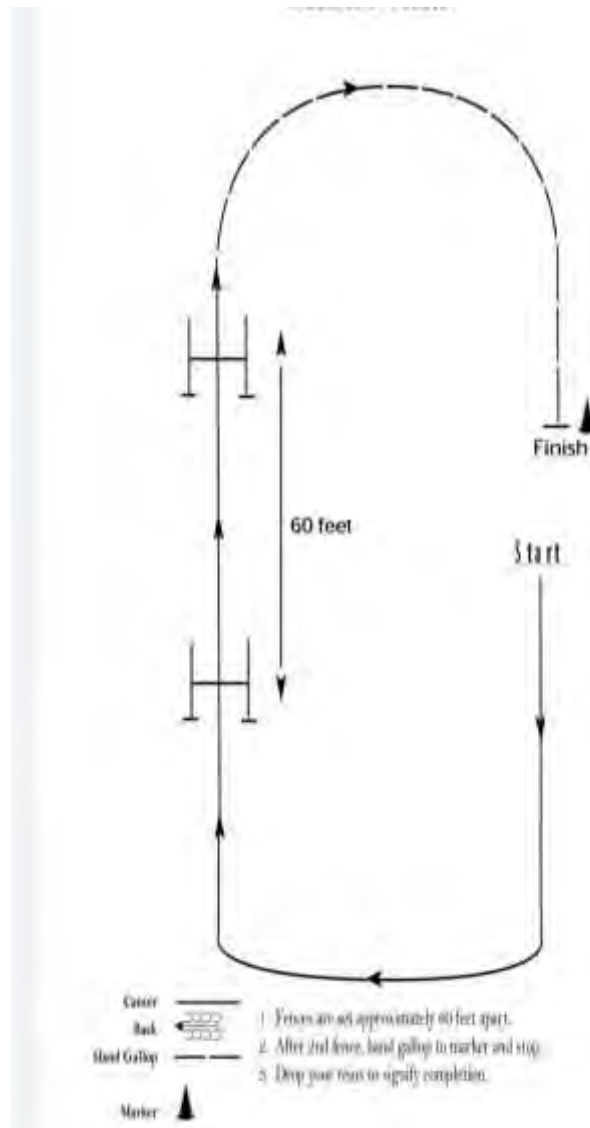

66. HUNTER HACK PATTERN #2

1. Fences are set 60 feet apart.
2. After second fence, hand gallop to marker.
3. Stop and back at least 5 steps.
4. Drop your reins to signal completion.



.66. HUNTER HACK PATTERN #3

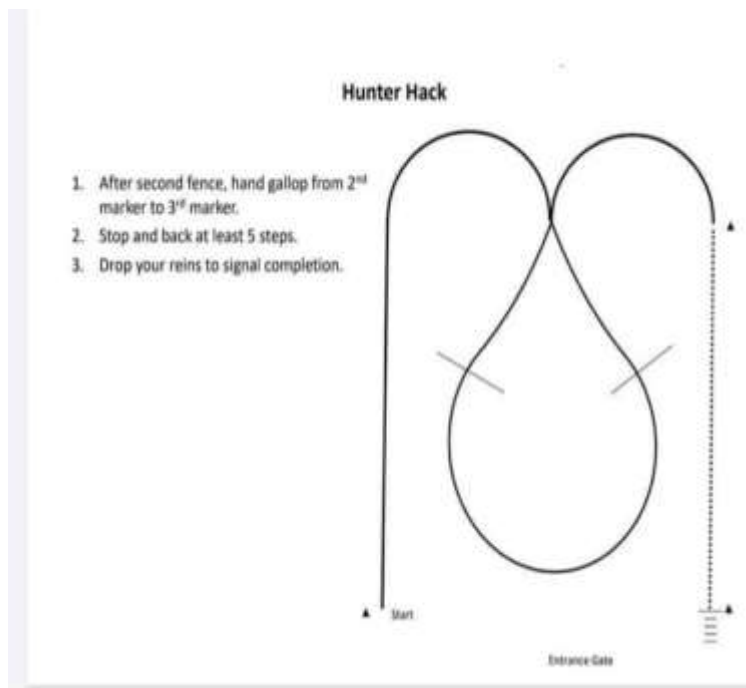

66. HUNTER HACK PATTERN #4



Beginning at the start of the cone, pickup left lead, Jump fence 1, make right hand turn, demonstrating a change of lead to Fence 2; Hand Gallop to the finish cone, stop, back, and drop reins to signify completion of pattern.

66. HUNTER HACK PATTERN #5

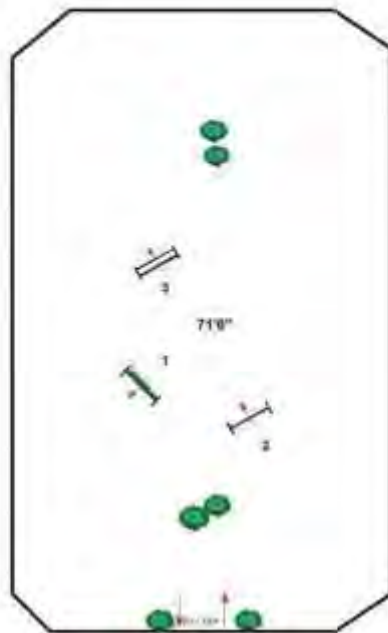

Beginning at the start of the cone, pick up right lead to Fence 1, demonstrating a change of lead, and completing the line of fences 2 and 3. Hand gallop to the finish cone, stop, back, and drop reins to signify completion of pattern.

### **67. WORKING HUNTER OVER FENCES:**

A. This class is designed to test pony and rider over a course of obstacles which may be found in the hunt field. The Judge should consider style of jumping, way of going, and manners. Pony is judged on ability to move smoothly through the course with even striding. Emphasis should be placed on safe jumping and fault any breaks in rhythm of stride caused by jumping too close or to far away from the fences, or jumping too high. Soundness is to be considered at the completion of the course.

B. Course should have minimum of four (4) different obstacles, and maximum of 10, and the (4) obstacles may be used to create (6) obstacles. These may be found in the hunting field, such as brush, in and out, box, rails, oxer, coop, cross bar and gate.

C. A triple bar, bales of hay or straw, and hop backs are not to be used. Ground rails are needed.

D. Obstacles should be 2' to 2'6" in height. Distance between elements should be at least 20' apart.

## **68. WESTERN PERFORMANCE DIVISION:**

A. All Western exhibitors must wear western hat, long sleeve shirt with collar, and western boots.

B. Ranch Horse Pleasure/Riding

C. Western Equipment

1. Hackamore: A flexible, braided rawhide, leather or rope bosal, with rawhide or flexible cable core. No other material may be used in conjunction with the hackamore.

2. Bits

a. Snaffle bit: Conventional O-ring, egg-butt or D Ring with a ring no larger than 4"

b. Curb bit: A curb bit with solid or broken mouthpiece, having shanks and acting with leverage. Curb bits must be free of mechanical device. Maximum shank length is 8 1/2"; fixed or loose shank Maximum port height is 3 1/2".

c. Bit mouthpieces 1. Bars of mouth piece must be, smooth, unwrapped metal of 5/16" or 3/4" in diameter, measured 1" from the cheek.

2. Mouthpiece may be two or three pieces. A three piece, connecting ring up to 1 1/4" diameter, or connecting flat bar 3/8 to 3/4" with maximum length of 2", which lies flat in mouth is permitted.

3. Junior Ponies (five and younger) may show in snaffle, curb, or bosal; and may be shown two-handed. Senior Ponies (six and older) must show in curb bit; and shown one-handed.

**69. REINS:**

A. Junior Ponies in curb bit, and all Senior ponies may only use one hand on reins; one finger only between split reins, no changing of hands.

B. Junior Ponies in snaffle bit or bosal may use two hands.

**70. WALK TROT HORSEMANSHIP:**

A. Points follow the exhibitor. Type, conformation and quality of the pony is to have no bearing on judging. Manners and response to the exhibitor however, indicate the degree of training received by the pony and should be credited to the exhibitor.

B. Entries to be judged at a walk and trot both ways of the arena. Rider shall maintain contact with the pony's mouth.

C. The judge may call for individual tests

**71. WESTERN HORSEMANSHIP:**

A. Points follow the exhibitor. Type, conformation and quality of the pony is to have no bearing on judging. Manners and response to the exhibitor however, indicate the degree of training received by the pony and should be credited to the exhibitor.

C. Entries to be judged at a walk, trot and lope, both ways of the arena. Rider shall maintain contact with the pony's mouth.

D. The judge may call for individual tests

**72. WESTERN PLEASURE:**

A. Ponies are to be shown at a walk, jog and lope, both directions of the ring, on reasonably loose rein without undue restraint. Pony should cover ground in a long, low frame. The poll should be no lower than the withers, with headset not behind the vertical. Ponies will be asked to back. At least 3 steps

B. The class shall be judged on performance, apparent ability to give a good pleasure ride, manners, condition, and conformation of the pony as it relates to the pony's way of going.



### **73. PLEASURE DRIVING:**

#### **A. Pleasure Driving Equipment**

1. Should include whip suitable to the cart, light horse breast collar harness to include surcingle with shaft tie downs and crupper, standard bridle, over check or check reins.

2. Only loose ring snaffle, half cheek snaffle, liverpool, elbow driving bit and Bradoon overcheck bits are acceptable. If a curb chain is used, it must be at least 1" wide, and lie flat against the jaw of the pony.

3. The cart shall be a two wheel, pleasure type, single pony cart with seating for one or two persons. Four wheeled carts viceroys are acceptable but not recommended. All carts shall be basket type, with, 24" to 48" rubber tired cart wheels. Stirrup- type carts or race sulkies are prohibited.

4. Action chains, weighted shoes, and bell boots are prohibited.

5. At judge's discretion, tails and bits may be checked.

B. Class should be judged 80 percent on the pony's performance and suitability for assuring a pleasurable drive, with a maximum of 20 per cent on condition and conformation.

C. A pleasure driving pony should carry itself in a natural balanced position with head and neck relaxed. The poll should be level with or slightly above the level of the withers.

D. Maximum credit should be given to the pony that moves straight, with free movement, manners and a bright expression.

E. The pony should be severely penalized if he carries his head behind the vertical, is over flexed, excessively nosed out, or the poll is below the withers. Excessive action shall also be penalized.

F. Ponies should enter the ring in the same direction. Each pony should be exhibit at a flat walk, slow trot, and extended trot. At the direction of the ring steward, change of direction should be made by having ponies cross the show ring while walking. Judge may ask driver to back pony and cart.

G. Driver shall be neat and properly dressed for a pleasure class. English or Western attire is acceptable but shall not be mixed. English or Western hats are optional. Baseball/ golf caps and visors are prohibited

#### **74. PEE WEE DIVISION :**

##### **74. LEAD LINE:**

- A. Points follow the exhibitor. Type, confirmation and quality of the pony is to have no bearing on judging.
- B. The class is judged based on the horsemanship of the rider, ground work of the leader, and overall appearance.
- C. Attire: Needs to correspond to the type of horse; i.e., western for stock type or hunter for hunt type.
- D. Entries to be judged at the walk both directions.
- E. Limited to exhibitors 6 years of age and younger
- F. Cannot show in any three gaited classes at the same show
- G. Can show in Walk & Trot

##### **74.WALK TROT PEE WEE**

- A. Points follow the exhibitor. Type, conformation and quality of the pony is to have no bearing on judging. Manners and response to the exhibitor however, indicate the degree of training received by the pony and should be credited to the exhibitor.
- B. Entries to be judged at a walk and trot both ways of the arena. Rider shall maintain contact with the pony's mouth.
- C. The judge may call for individual tests.

##### **74. PEE WEE TRAIL**

- 1. Points will follow the Exhibitor
- 2. Judged only at a walk and on the rider and pony's ability to negotiate the pattern
- 3. Rider may use a adult or leader in this class
- 4. Attire needs to correspond to the type of horse, stock type for western; hunt type for English

#### **74. PEE WEE DIVISION continued:**

##### **74. TRAIL WALK TROT PEE WEE 10& UNDER**

A. This class will follow all Rule #73 TRAIL; other than no 3 gaited maneuvers will be used for this class. It is designed for the young rider, or young horse wanting to compete in Trail, but have not accomplished 3 correct gaits.

B. Patterns will be the same as a regular IN-Trail pattern (as there is not three(3) gaits.

C. Once pony/rider combination competes in a regular Trail Class as defined by Rule #73; they no longer meet the eligibility requirements of this class.

**D. Pee Wee Riders are Not allowed a handler in this class**

##### **74. PEE WEE CONTESTING**

1. 10 years and younger NQPA members are eligible for this class.
2. Exhibitor May have a handler
3. Points will be in the Individual Category
4. **In Any riding class, if more than 3 strides of a canter/lope is used, this can be a disqualification.**

##### **75. TRAIL WALK TROT**

A. This class will follow all Rule #74 TRAIL; other than no 3 gaited maneuvers will be used for this class. It is designed for the young rider, or young horse wanting to compete in Trail , but have not accomplished 3 correct gaits.

B. Patterns will be the same as a regular IN-Trail pattern (as there is not three(3) gaits.

C. Once pony/rider combination competes in a regular Trail Class as defined by Rule #73; they no longer meet the eligibility requirements of this class.

**D. Pee Wee Riders are Not allowed a handler in this class**

## **76. TRAIL:**

A. This class shall be judged with emphasis on performance and willingness of pony over obstacles, obedience to rider, and performance at gaits; 70% on work over obstacles; 30% on manners and responsiveness. Course shall be designed so that the pony demonstrates all three gaits.

B. At least five obstacles shall be used, and should be picked from the following list:

1. Walk over logs, 16" to 24" apart (they can be elevated a maximum of 8")
2. Trot over logs spaced 3' to 3'6"
3. Lope over logs 6' to 7'
4. Ride over a wooden bridge or simulated water hazard.
5. Ground tie pony (only in a enclosed arena)
6. Back through L' shaped course or serpentine course
7. Side pass an obstacle
8. Open, pass through, and close a gate
9. Open mailbox, remove contents, replace contents, close mailbox
10. Carry an object from one location to another
11. Approach a slicker, pick it up, rub over pony, replace slicker
12. Execute a turn of any degree in a box.
13. Ride pony through two obstacles simulating a narrow passage
14. Any obstacle can be elevated in Trail with the exception of lope over logs.
15. A steer head or calf head or roping dummy may be used, as a obstacle

C. The exhibitor shall be required to move to the next obstacle after three (3) refusals on any one obstacle

D. Change of hands on reins permitted only if required for execution of specific obstacle, after which reins must be returned to previous positioning.

## **77. IN HAND TRAIL:**

A. This class shall be judged with emphasis on performance and willingness of pony over obstacles, obedience to handler, and performance at gaits. Each maneuver shall be scored 0-10 points

B. A pony can be shown in Trail and In Hand Trail at the same show.

C. Equipment shall consist of a leather, rope, or nylon halter and appropriate lead. Exhibitor shall wear appropriate attire as outlined in this rulebook.

D. In the case of a refusal (handler backing up from an obstacle, sidestepping, turning) the exhibitor may attempt the obstacle a second time. If obstacle is refused a second time, exhibitor shall proceed to the next obstacle.

E. The handler may touch the pony to cue it.

F. At least five obstacles shall be used, and should be picked from the following list:

1. Walk over logs, 16" to 24" apart (they can be elevated a maximum of 8")
2. Trot over logs spaced 3' to 3'6
3. Walk over a wooden bridge or simulated water hazard.
- 4.. Ground tie pony (only in a enclosed arena)
5. Back through L' shaped course or serpentine course
- 6.Side pass an obstacle
7. Open, pass through, and close a gate
8. Open mailbox, remove contents, replace contents, close mailbox
9. Carry an object from one location to another
10. Approach a slicker, pick it up, rub over pony, replace slicker
11. Execute a any degree turn in a box
- 12.Have pony go through two obstacles simulating a narrow passage.
13. A steer head, or calf head, or roping dummy may be used in obstacles

**78. GROUND ROPING:**

- A. Points follow the exhibitor
- B. Attire is the same as for Western Horsemanship
- C. Exhibitors stand at a marked line of 2 feet behind the bale or what is used for head
- C. Each exhibitor will get three throws and each throw is given a score of 0-10 points for each of the following:
  - 1. Building of the loop
  - 2. Flat 3 point swing
  - 3. Delivery of loop and accuracy
  - 4. Pulling and pitching
- D. In the event of a tie, the exhibitors with the tied scores will be backed up at two feet increments until the tie is broken.

**79. EGG & SPOON:**

- A. Eggs and spoons will be provided by the Association.
- B. Points follow the exhibitor.
- C. Contestants must walk, trot, and lope as instruction of the judge.
- D. The spoon must be held at the end of it and the arm must be fully extended.
- E. Western hat, helmet, or no hat at all are permissible
- F. At the discretion of the judge, failure to follow instructions may result in disqualification
- G. Contestants shall follow directions of the judge, however the following shall NOT be permitted:
  - 1. No sitting behind the saddle
  - 2. No holding the spoon in the mouth
  - 3. No jumping over jumps
  - 4. Riders must keep one hand on the reins at ALL times
  - 5. Riders must always be astride the pony
  - 6. Any other action that may be deemed dangerous by the NQPA
  - 7. Once the class starts the exhibitor cannot touch the egg in anyway

## **80. GENERATION HORSEMANSHIP:**

### **A. Points will follow the exhibitors**

- B. Each rider team will earn NQPA points for this class .
- C. There must be thirteen (13) years difference in riders ages; thereby being a generation apart.
- D. The older team rider shall exhibit the animal first way around the arena, all gaits, come to the center of ring, dismount and exchange rider, with the younger rider exhibiting the pony the opposite way of the arena.
- E. The placing of the two riders are averaged together by the judge to determine placing in the class.
- F. The Judge may ask for individual tests.

## **81. RANCH PLEASURE /RIDING RULES REGULATIONS**

- A. Ranch Horse Pleasure is an event to demonstrate the Versatility of the animal. Ability to change leads smoothly, responsiveness to the rider, and calmness and ability to maneuver any obstacles should reflect the horse riding outside a arena and looking at a long ride to go to work.
- B. Animals will work both ways of the arena, {in rail work sessions} walk, trot,/jog, lope; and to follow pattern, which should include all three gaits. Extended gaits will be called, as in ; extended walk, extended trot, extended lope. In the trot/jog or extended; exhibitors May post, or stand in stirrups. Animals will also be expected to reverse direction and back.
- C. Attire, Shall be Ranch type, ( jeans, long sleeved shirts with collars, button down shirts, boots and hats are normal attire), children 19 and under May also wear Safety Helmets. Chaps are to the Exhibitors discretion.
- D. Tack, No excess Silver, on saddles, bridles; animals under 5 , may show two handed, animals 6 and over must show one handed with shank bit.
- E. Judges may ask for additional work
- F. NQPA ponies May enter both types of Pleasure as long as rules are followed for both.
- G. **Credits;**
  - 1. Free Flowing gaits, balanced correct gaits
  - 2. Giving appearance of doing a days work
  - 3. Smooth transitions
  - 4. Working off hindquarters while turning
  - 5. Working on a reasonable loose rein, without excessive cueing
  - 6. Appropriate tack
  - 7. Appropriate clothes or attire
  - 8. Following and executing pattern flawlessly

## **81. Ranch Pleasure Continued**

H. **Faults** {to be penalized according to severity}

1. Wrong Lead
2. Breaking gait
3. Excessive silver
4. Excessive speed, any gait
5. Head Carriage to low, But if horse completes more than strides with the head to low this will be a DQ

### **I. Disqualifications**

1. Hoof black/polish
2. Fake Tails
3. Banded or braided manes or tails
4. Horse and or rider falling
5. Failure to follow pattern
6. Fancy, blingy clothes
7. Failure to display number

J. Ranch Pleasure as a NQPA point class, began in 2015 and 3 patterns will be offered to exhibitors to choose from, Ranch pleasure will be a Rail Class

K. In 2017 the Ranch Pleasure Class shall be split between adult and youth.

Guidelines for this rail class;

Horse/pony to be shown as natural as possible ,fake tails, banded manes, braided manes are not allowed. excess silver on saddle, bridle is discouraged. Class is judged on manners, quality of movement, and responsiveness to rider, Maximum credit will be given to a flowing, balanced and willing pony/horse and that gives the appearance of being fit, alert, and a pleasure to ride; and a pony/horse that possesses great athletic ability and agile.

All entries show all gaits, both ways of arena, at working speed, passing is permissible , as long as pony/horse maintains proper cadence and rhythm . Extended gaits must be asked for, all contestants will be required to back



## **82. RANCHMANSHIP**

The purpose of this class is to bring forth the versatility in the ranch horse and exhibitor, in the task of performing 1 of 3 designated patterns, constructed of Trail and Reining maneuvers. Obstacles and maneuvers are to be judged to the standards of Trail, and Reining that pertain to these classes.

1. Each horse will work individually performing one (1) of three (3) patterns offered in the rulebook.
2. There will be no time limit
3. A simple or flying lead change should be executed precisely at the designated location. A simple lead change is performed by breaking to a walk, or trot for one to five strides. Flying lead changes should be simultaneous front and rear. All changes should be smooth and timely.
4. This class will be judged on quality of movement. Transitions should be performed where designated, with smoothness and responsiveness. Posting at extended trot is acceptable. Exhibitor may not hold the saddle horn.
5. Exhibitor will be judged on ability and decision making in the show pen. The exhibitor that puts their horse in the correct positions and making the horses job easier should receive credit

82. Ranchmanship

Pattern 1

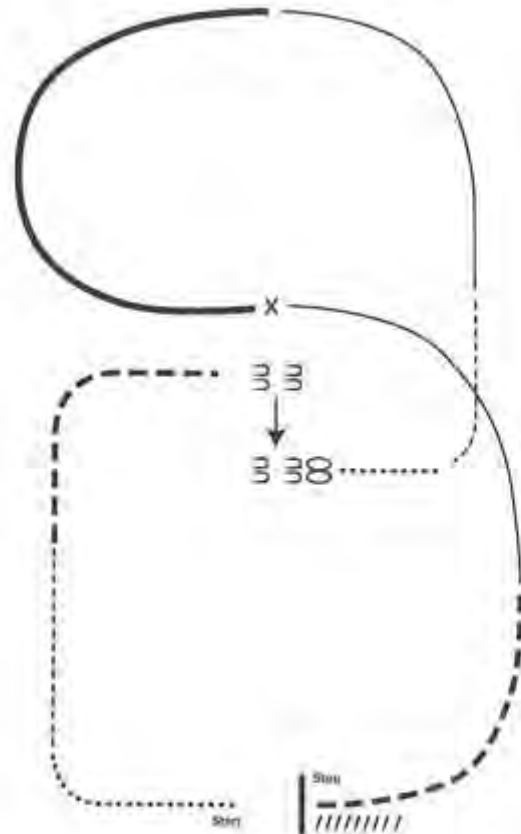

- ..... Walk
- Trot
- - - - - Extended Trot
- Lope
- Extended Lope
- ////// Back
- X Lead Change

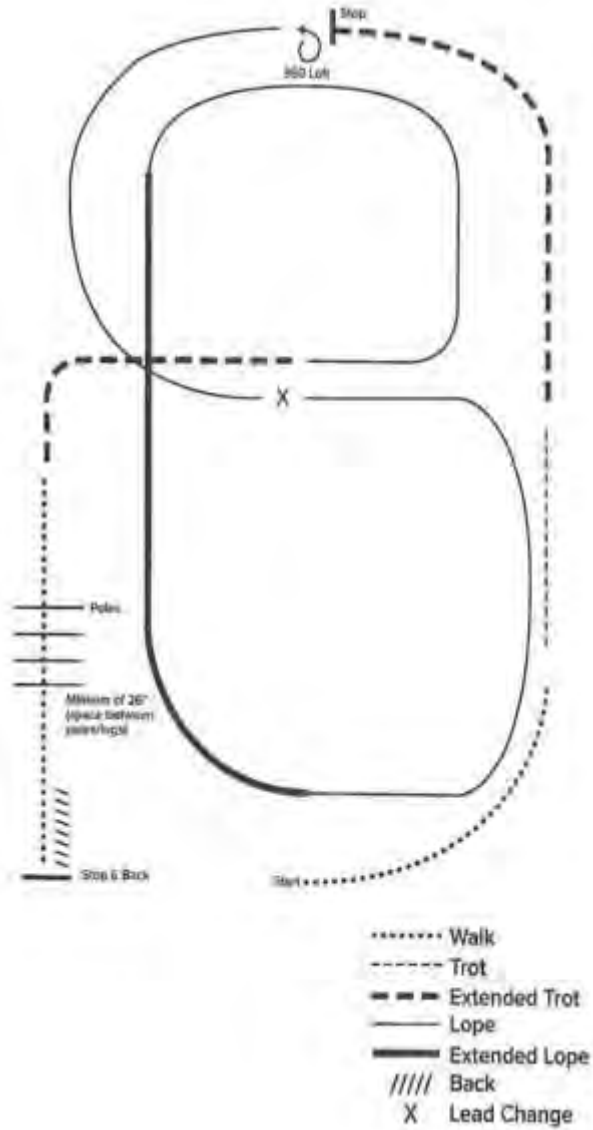

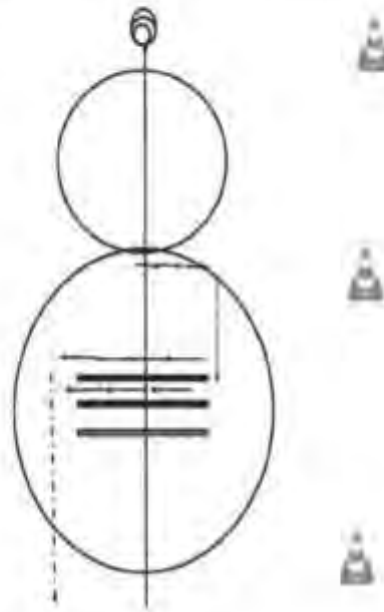
**RANCHMANSHIP PATTERN # 3**

1. Left lead lope down center of arena over poles past the end marker; stop.
2. 3 1/2 spins left.
3. Lope Right lead to center of pen, Turn right lope small slow circle change to left lead.
4. Lope large fast circle stop in center of pen.
5. Back 6-8 feet 90 turn left.
6. Walk to the first pole exhibitor comes to and side passes to the right.
7. Exit at trot to end of arena.

### 83. WESTERN RIDING:

A. Western Riding is an event where the horse is judged on quality of gaits, ability to change leads smoothly, responsiveness to the rider, manners, and disposition.

B. The horse should maintain an even cadence of gait and change leads precisely and easily, front and rear simultaneously, at the center point between markers as indicated by the shaded areas on the pattern. The horse should have a relaxed head carriage showing response to the rider's hands, with moderate flexion at the poll. The tail may lift with each lead change but should not show resistance by excessive use or wringing. The horse should cross the log at the jog/pleasure gait and lope without breaking gait or radically changing stride.

C. Tack, attire, and method of handling the reins are the same as for western horsemanship.

D. The markers should be pylons. In the row of five markers, the markers are separated by an equal distance of 30 to 50 feet. The markers in the row of three are aligned with the first, third, and fifth markers in the row of five. All Pylons should be at least 15 feet from the arena fence, and the width of the pattern should be 50 to 80 feet.

E. Scoring will be on a basis of 0 to 100, with 70 indicating an average performance. Each rider begins with a 70 score and has points added for excellence or deducted for poor performance for each maneuver.

1. Scoring guidelines to be considered: Points will be added or subtracted for the maneuvers on the following basis: + 1-1/2 = excellent, + 1 = very good, + 1/2 = good, 0 = average, - 1/2 = poor, -1 = very poor, and - 1-1/2 = extremely poor. Maneuver scores are to be determined independently of penalty points. The 12 maneuvers are listed with the pattern.

**83. WESTERN RIDING continued:**

2. Penalty points will be given for each occurrence

A. Five points:

1. Failure to change leads
2. Kicking out
3. Willful disobedience

B. Three points

1. Not performing the specific gait or not stopping within 10 feet of the designated area.
2. Break of gait at lope.
3. Simple lead changes.
4. Failure to change after one stride, but changes before the next designated change area.
5. Additional lead changes anywhere on pattern.
6. Failure to lope within 30 feet after crossing the log.
7. Break of gait at walk or jog for more than two strides

C. One point

1. Break of gait at walk or jog up to two strides.
2. Hitting or rolling the log.
3. Failure to change leads for one stride.
4. Splitting the log between the two front or two rear feet.

D. One/half point

1. Tick or light touch of the log
2. Hind legs skipping or coming to
3. Failure to change leads for one half to one stride.

### **83. WESTERN RIDING CONTINUED:**

#### **E. Disqualified**

1. Fall to the ground by the horse or rider
2. Illegal equipment or willful abuse
3. Off course, knocking over markers, or completely missing the log.
4. An incomplete pattern incorrect or failure of maneuvers, passing on the wrong side of markers, or extra loops in the pattern

#### **F. The following are considered as faults and should be judged accordingly in maneuver scores.**

1. Opening mouth excessively or raising head on maneuvers
2. Anticipating signals, or early lead changes.
3. Stumbling

#### **G. Credits which should be scored in maneuver scores are:**

1. Simultaneous front and rear lead changes
2. Lead changes at designated areas.
3. Accurate and smooth patterns.
4. Even pace throughout.
5. Easy to guide and control with rein and leg.
6. Good manners and disposition.
7. Physical fitness of the pony.

WESTERN RIDING

**Maneuvers for Western Riding Pattern**

1. Walk to the first pylon and begin jogging to and over the log.
2. Transition to left lead lope and lope around the pylon.
3. First line change.
4. Second line change.
5. Lope around pylon.
6. Lope around pylon and first crossing change.
7. Second crossing change.
8. Lope over log.
9. Third crossing change.
10. Fourth crossing change.
11. Lope up the center, stop, and back.

WALK - - - -      BACK ← - - - -  
 JOG - · - -      LEAD CHANGE //  
 LOPE ————



## WESTERN RIDING

**Maneuvers for Western Riding Pattern**

1. Walk to the first pylon and begin jogging to and over the log.
2. Transition to a lope to the left around the next cone.
3. First crossing change.
4. Second crossing change.
5. Third crossing change.
6. Circle and first line change.
7. Second line change.
8. Third line change.
9. Fourth line change and circle.
10. Lope over log.
11. Stop and back.

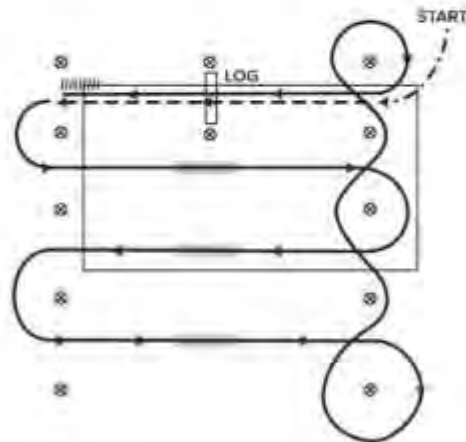

WALK: - - - - - JOG: - - - - -  
 LEAD CHANGING AREA: [diagonal lines] LOPE: ————

**WESTERN RIDING PATTERN**

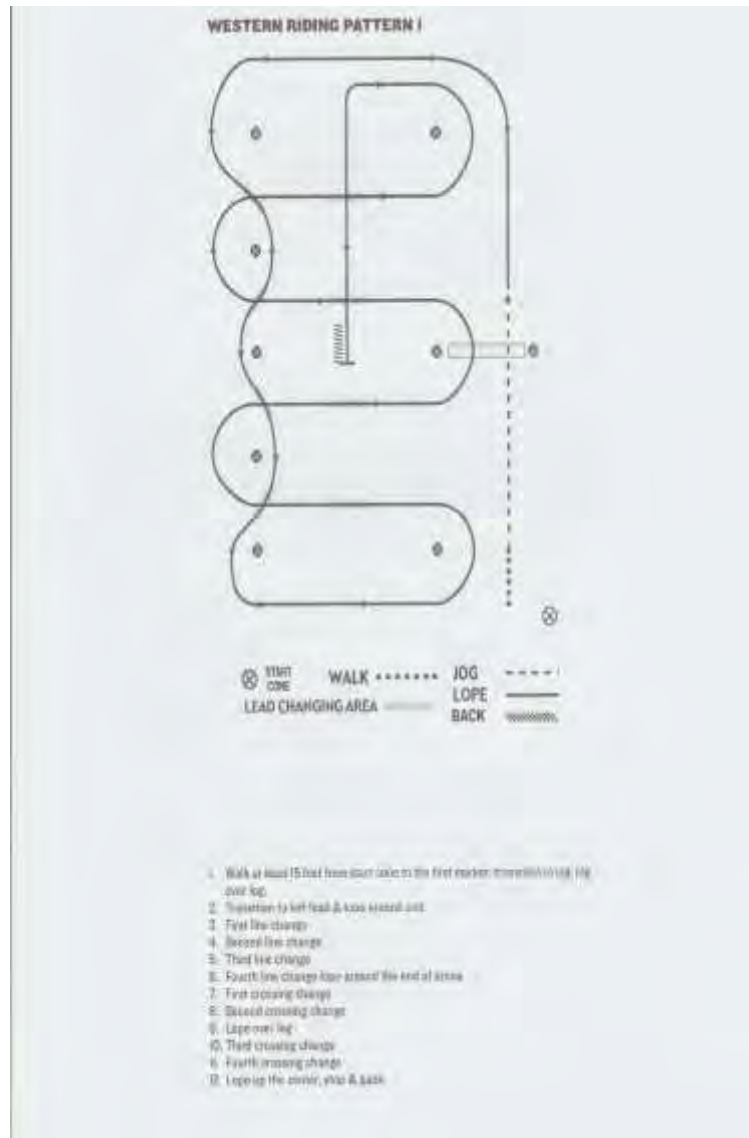

## **84. REINING**

- A. Each pony should be judged on the ease, dispatch and calmness with which it performs the pattern.
- B. Pony should rein and handle easily, fluently, effortlessly, and with reasonable and controlled speed throughout the pattern.
- C. Scoring is on the basis of 60-80 with 70 denoting an average performance.
- D. Faults Against the Pony:
  - 1. Excessive jawing, open mouth, or head raising on stop
  - 2. Breaking gaits
  - 3. Refusing to change leads
  - 4. Anticipating signals
  - 5. Stumbling or falling
  - 6. Wringing of tail
  - 7. Bouncing or sideways stop
  - 8. Backing sideways
  - 9. Refusal to change leads as specified in pattern
- E. Faults Against the Rider
  - 1. Changing hands on reins
  - 2. Losing stirrup
  - 3. Two hands on reins of a bitted pony
  - 4. Unnecessary aids given by the rider (talking, petting, spurring, jerking of reins) should be considered faults and scored accordingly.
  - 5. Falling of pony
  - 6. Touching saddle with either hand

## **REINING PATTERN ONE (1)**

A. Simple Lead Change (done through the walk or trot)

B. Flying Lead Change.

Ride patterns as follows.

Maneuver 1

Lope in a straight line down the center of the arena  
past

the second cone and stop.

Maneuver 2

Back to center of pattern, pivot right.

Maneuver 3

Lope a large fast circle to the left, then a slow small  
circle,

then a large fast one.

Maneuver 4

Change lead.

5. Lope a large fast circle to the Right, followed by a  
small slow circle, then another large fast circle.

6. Change lead and lope a large fast loop around the  
end of the circle made to the left, straighten your pony  
and run down past the center marker.

7. Stop, back up, and report to Judge for inspection.

Reining Pattern 1

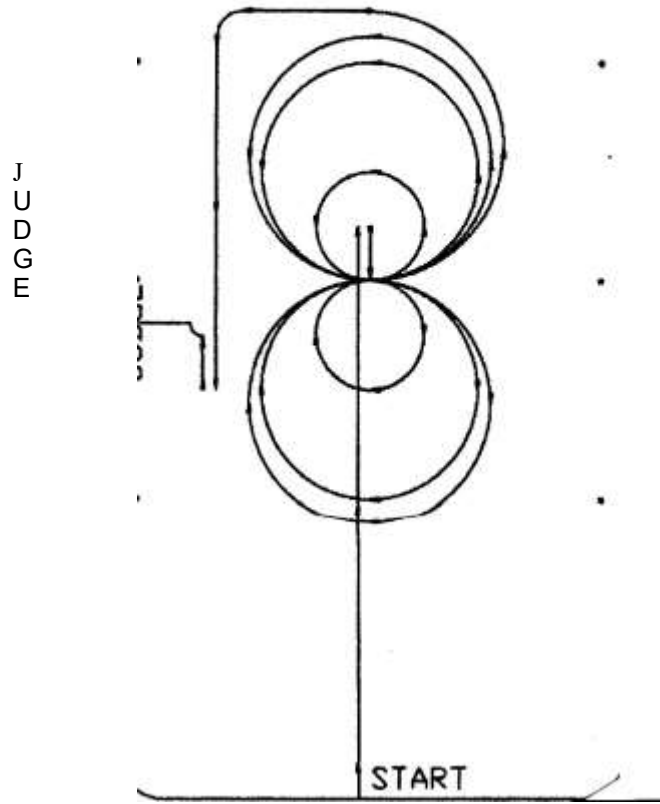

### **REINING PATTERN #2**

1. Walk to the center of the arena, facing the left wall.
2. Spin once to the left
3. Spin once to the right
4. Depart on the right lead, completing one small slow Circle, and one large fast circle
5. Change leads in the center of the arena.
6. On the left lead, perform one small slow circle, and one large fast circle.
7. Change leads in center of arena
8. On the right Lead, begin a large fast circle, but do not close it, Run down the right wall of the arena, 20 feet off the rail, past the center marker, stop and roll back to the left.
9. Run around the top of arena, down the left wall 20 feet off the rail, past the center marker, stop and rollback to the right.
10. Run around the top of the arena, down the rightwall, 20 feet off the rail, past the center marker, stop and back at least 10 feet.

REINING PATTERN #2

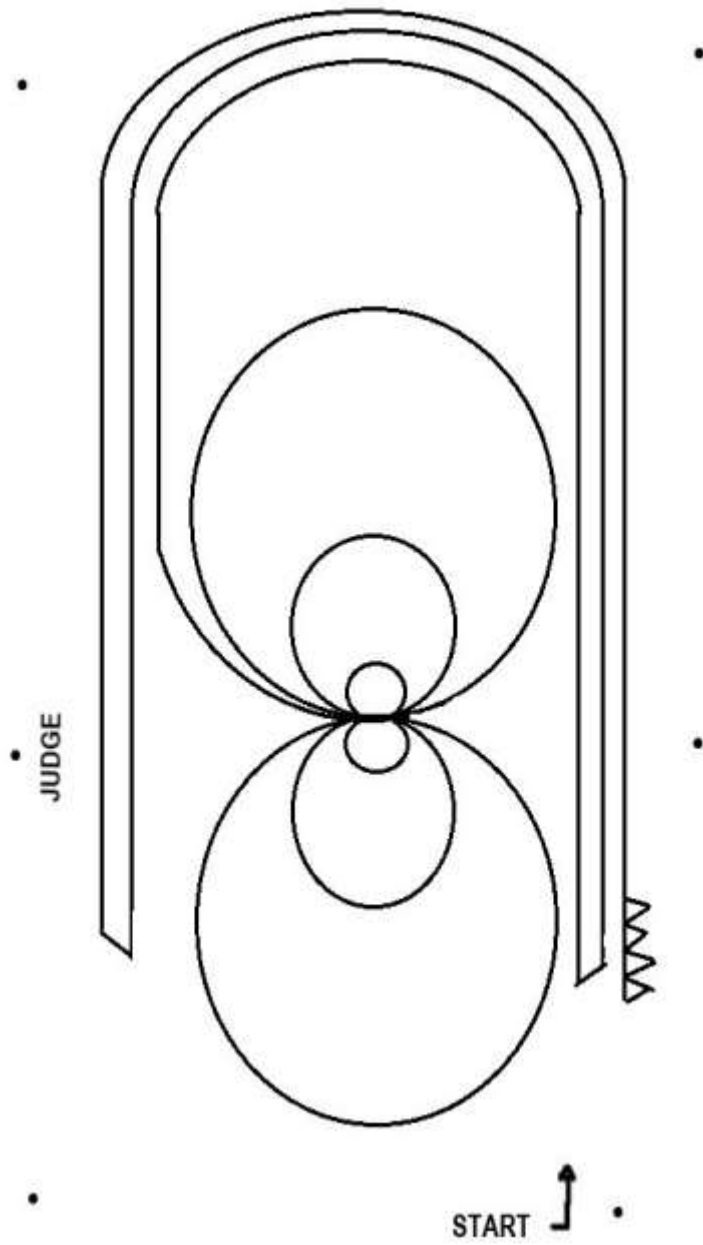

### **REINING PATTERN THREE (3)**

**Maneuver 1**

Walk to the center of the arena and complete two spins to the right. Hesitate

**Maneuver 2**

complete two spins to the left. hesitate

**Maneuver 3**

Begin on the left lead, complete two large fast circles to the left. Make one small, slow circle to the left. Change leads.

**Maneuver 4**

complete two large, fast circles to the right and one small, slow circle to the right, change leads.

**Maneuver 5**

Begin a large fast circle to the left. Do not close this circle, but run down the side past the center marker and do a right rollback at least twenty(20) feet from the arena fence.

**Maneuver 6**

Continue back around previous circle, run down opposite side of arena past center marker and do a left rollback at least twenty (20) feet from the arena fence.

**Maneuver 7**

Continue back around previous circle. Do not close this circle, but run down the side past center marker and do a sliding stop. Back straight to the center of the arena or a least ten (10) feet.

Hesitate to indicate completion of pattern and report to Judge for inspection.



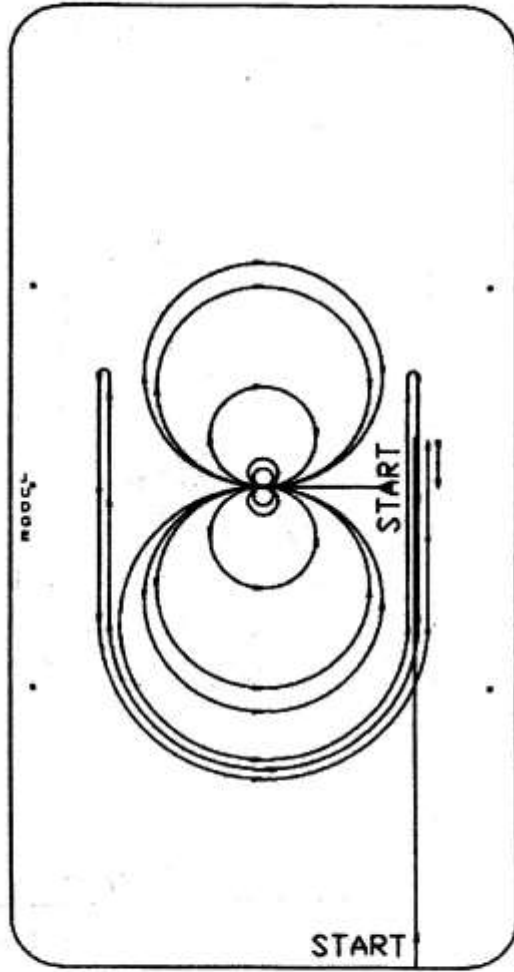

REINING PATTERN 3

#### **REINING PATTERN FOUR (4)**

1. Run at speed to the far end of the arena past the end marker and do a left rollback - no hesitation.
2. Run to the opposite end of the arena past the end marker and do a right rollback- no hesitation
3. Run past the center marker and do a sliding stop Back up to center of the arena or at least ten feet (3 meters). Hesitate.
4. Complete four spins to the right.
5. Complete four and one-quarter spins to the left so that horse is facing left wall or fence. Hesitate.
6. Beginning on the left lead, complete three circles to the left: the first circle large and fast; the second circle small and slow; the third circle large and fast. Change leads at the center of the arena.
7. Complete three circles to the right: the first circle large and fast; the second circle small and slow; the third circle large and fast. Change leads at the center of the arena.
8. Begin a large fast circle to the left but do not close this circle. Run straight up the right side of the arena past the center marker and do a sliding stop at least twenty feet (6 meters) from wall or fence. Hesitate to demonstrate the completion of the pattern.

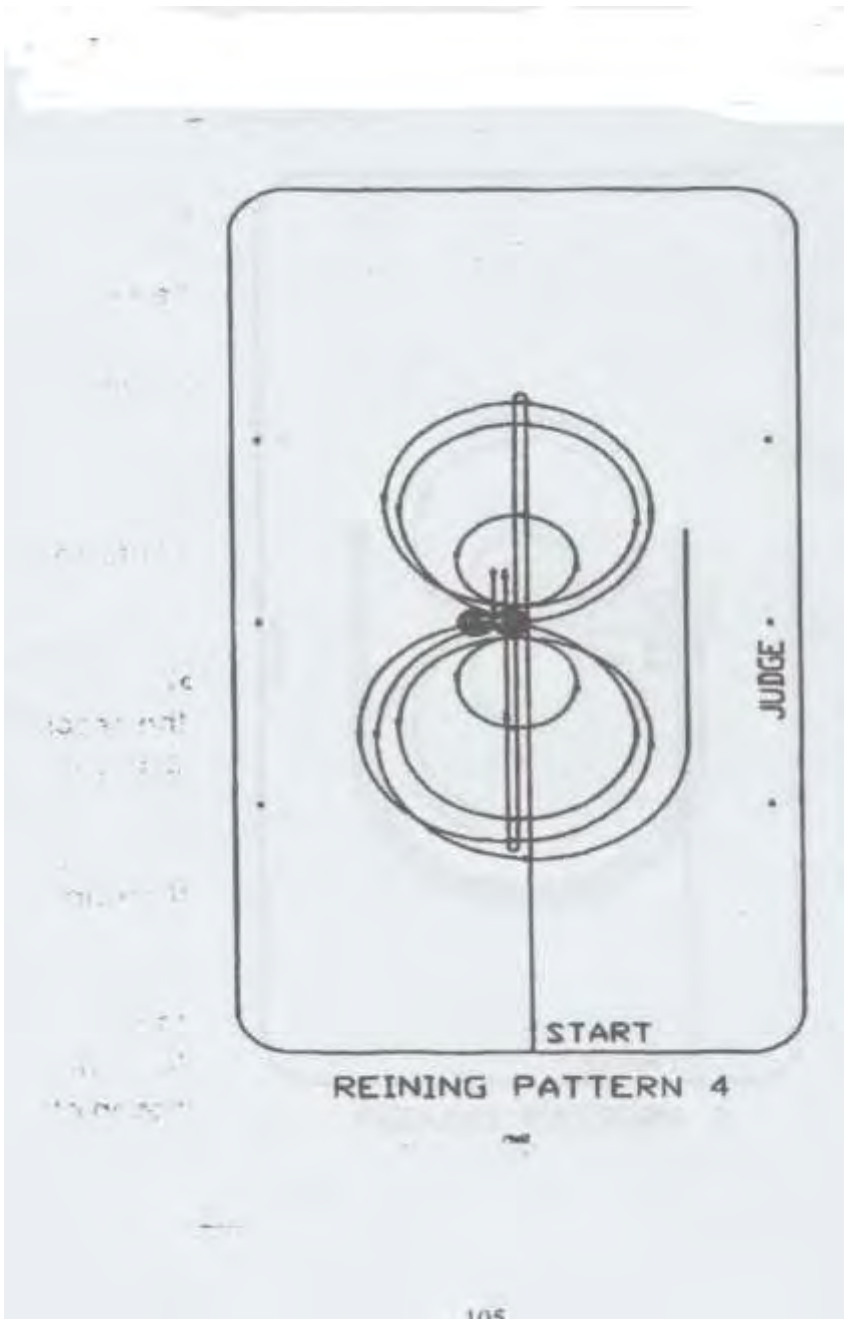

### **REINING PATTERN FIVE (5)**

1. Beginning, and staying at least twenty feet from the fence, lope straight up the left side of the arena, circle the top end of the arena, run straight down the opposite side or right side of the arena past the center marker and do a left rollback – no hesitation.
2. Continue straight up the right side of the arena staying at least twenty feet from fence, circle back around the top of the arena, run straight down the left side of the arena past the center marker and do a right rollback - no hesitation.
3. Continue up the left side of the arena to the center marker. At the center marker, the pony should be on the right lead. Guide the pony to the center of the arena on the right lead and complete three circles to the right: the first two circles large and fast: the third circle small and slow. Change leads at the center of the arena.
4. Complete three circles to the left: the first two circles large and fast: the third circle small and slow. Change leads in the center of the arena.
5. Begin a large fast circle to the right but do not close this circle. Continue up the left side of the arena staying at least twenty five feet from the fence, circle the top of the arena, run straight down the opposite or the right side of the arena past the center marker and do a sliding stop. Back up at least ten feet. Hesitate.
6. Complete four spins to the right.
7. Complete four spins to the left. Hesitate to demonstrate completion of the pattern.

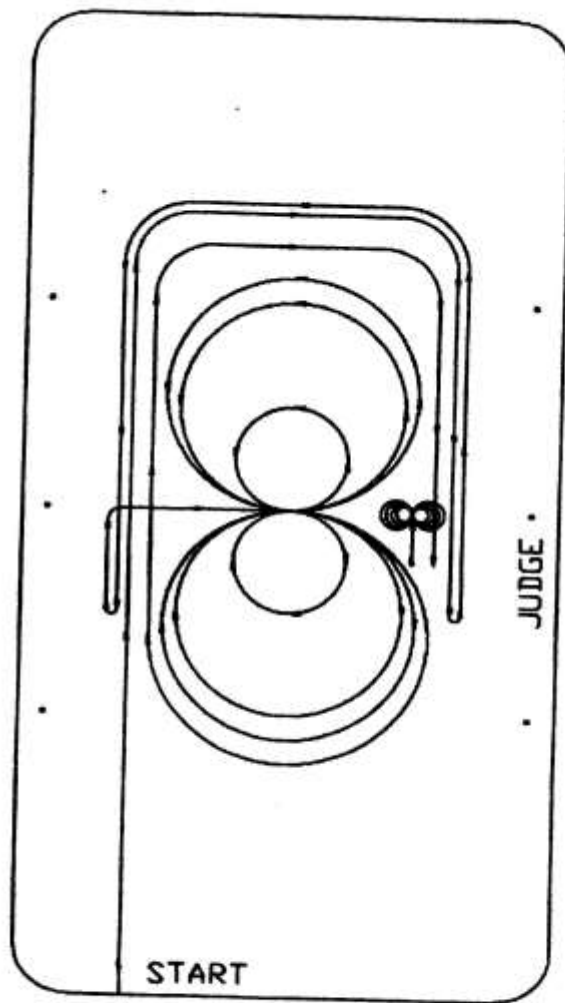

REINING PATTERN 5

### REINING PATTERN SIX 6

Ponies may walk or trot to the center of arena. Ponies must walk or stop prior to starting pattern. Beginning at the center of the arena facing the left wall or fence.

1. Beginning on the right lead, complete three (3) circles to the right; the first circle small and slow, the next two circles large and fast. Change leads at the center of the arena.
2. Complete three (3) circles to the left; the first circle small and slow, the next two circles fast and large. Change leads at the center of arena.
3. Continue around the previous circle to the right. At the top of the circle, run down the middle to the far end of the arena past the end marker and do a **LEFT** rollback-no hesitation.
4. Run up the middle to the opposite end of the arena past the end marker and do a **RIGHT** rollback—no hesitation.
5. Run past the center marker and do a sliding stop. Back up to the center of the arena or at least 10 feet Hesitate.
6. Complete four (4) spins to the right. Hesitate
7. Complete four (4) spins to the left Hesitate to demonstrate the completion of the pattern.

REINING PATTERN # 6

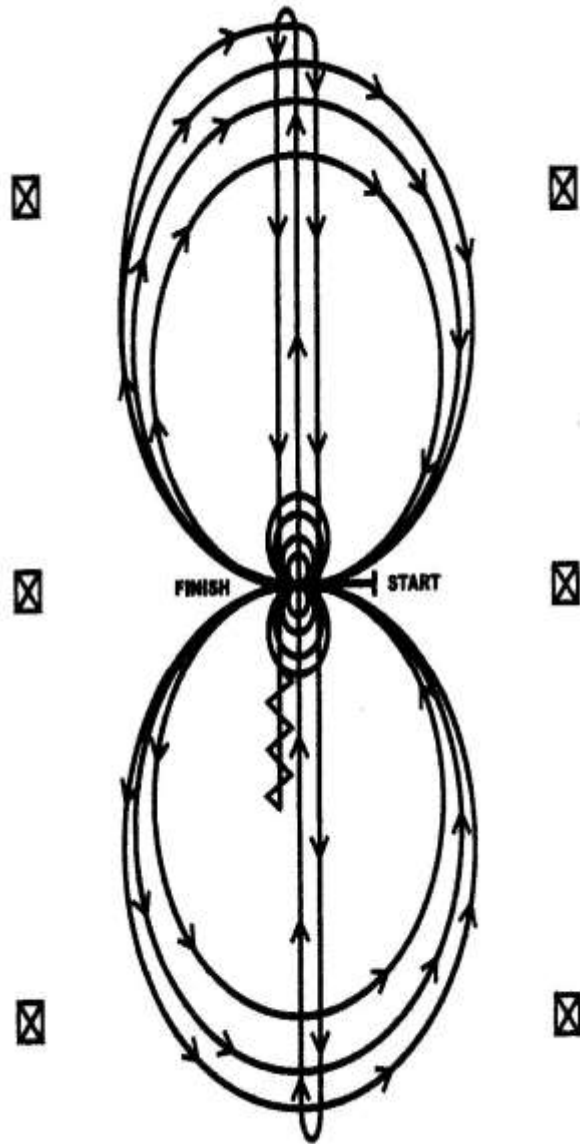

**85.FREESTYLE REINING:**

**A. All related NQPA rules and regulations apply to the Free Style Reining events**

**B. Minimum time: 3 minutes**

**C Compulsory Maneuvers**

1. 1 Lead change to the right.
2. 1 Lead change to the left.
3. 3 Stops.
4. 4 Spins to the right.
5. 4 Spins to the left.

**D. Faults**

1. Touching pony or saddle with hands. (unless props are used in competition)
2. Disobedience or resistance of the pony.
3. Rider's lack of control of the pony.
4. Pony rearing.
5. Pony biting
6. Excessive tail wringing

**E. General:**

1. Exhibitors shall provide their own music, (CD, other) to the announcer at least 15 minutes before the start of the class. Exhibitors name shall be affixed on the music. If CD has more than one song recorded on it, the number of the correct song should be affixed to the CD. Reining pattern should be choreographed closely with the music chosen. Costumes and props shall be secure and above all safe



## 86. RIDER RECOGNITION PROGRAM

This program is for members and their animals to receive awards for hours put in the saddle, driving, or going to horse shows and competing.

The rules of the program are quite simple:

1. Individuals must complete an official application supplied by National Quarter Pony Association; and maintain a yearly membership.
2. A one time enrollment fee of \$25.00 ( Lifetime ) must accompany the application.
3. Failure to maintain NQPA membership shall result in for forfeiture of any hours accrued, in that given year.
4. All hours accrued either riding, or driving in harness on a Registered NQPA pony. The name and registration number of each pony listed on a separate log sheet (provided by NQPA ). Any number of National Quarter Ponies may be ridden to accumulate official hours. Awards are based on number of hours ridden or driven by an individual.
5. There is no time limit for the completion of an award level; however, continuous membership must be maintained to receive awards.

### ACHIEVEMENT LEVELS

50 HOURS  
100 HOURS  
250 HOURS  
500 HOURS  
750 HOURS  
1000 HOURS

6. NQPA RESERVES THE RIGHT TO CHANGE TERMS OR CONDITIONS OF THESE RULES AS WELL AS THE AWARDS.

As rider hours in the program increase, the recognition levels will be 2000-3000-4000-5000  
RIDER is allowed a maximum of two (2) hours per horse show.

## **87. CONTEST DIVISION**

A. Exhibitor may wear a western hat, safety helmet, or no hat. There is no penalty for loss of the hat. **Long sleeve shirt with collar shall be required.**

B. Ponies shall be shown with western or barrel racing saddle and western-type equipment shall be used.

C. An Electric Timer or at least 2 stop watches shall be used, averaging the two times.

D. A clearly visible starting line should be provided, the pony should be on the course when crossing the starting line. Timing begins when the pony's nose reaches the starting line and stop when pony's nose reaches the finish line.

E. Penalties are added to determine placing. Lowest time including penalties wins. Timer failure entitles rider to a re run In case of a tie, there must be a runoff unless one contestant concedes.

F. Exhibitor must enter the arena mounted on the pony and start your run within 2 minutes from the time your called. If a gate is available, it shall be closed during the run.

G. Disqualification of run if exhibitor grabs or touches any equipment; ie: pole (s) barrel (s) pylon (s), ect or goes off pattern

H. Pee Wee Poles and Barrels (10 & under) MAY be allowed a handler

**I. PEE WEEs must only Walk Trot, if more than 3 strides are used this may be a disqualification.**

**J. There will be no hitting of the horse in front of the saddle; this can be a disqualification.**

---

**POLE BENDING:**

A. The pole bending pattern is to be run around six (6) poles. Poles are placed twenty-one(21) feet apart and the first pole is 21 feet from the starting line. Poles should be set on the ground, six feet in height, and with a base no more than 14 inches in diameter.

B. A pony may start either to the right or left of the first pole and run the remainder of the pattern accordingly.

C. A five (5) second penalty will be added for each pole knocked over.

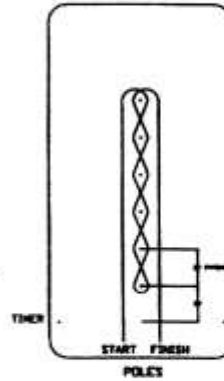

## STAKES RACE

1. Two (2) poles are to be used.
2. The horse and rider run down to the right or left side of the poles to the second pole, making either a right or left-hand turn. The exhibitor shall then run to the first pole and make a turn in the opposite direction. Exhibitors then run back to the second pole and repeat the first turn then run straight back to the start/ finish line.
3. The exhibitor shall not cross between the two (2) poles before making the first turn or after the third turn.
4. Any poles knocked over or failure to do a correct pattern will result in a 'No Time'.

### Stakes Race Pattern

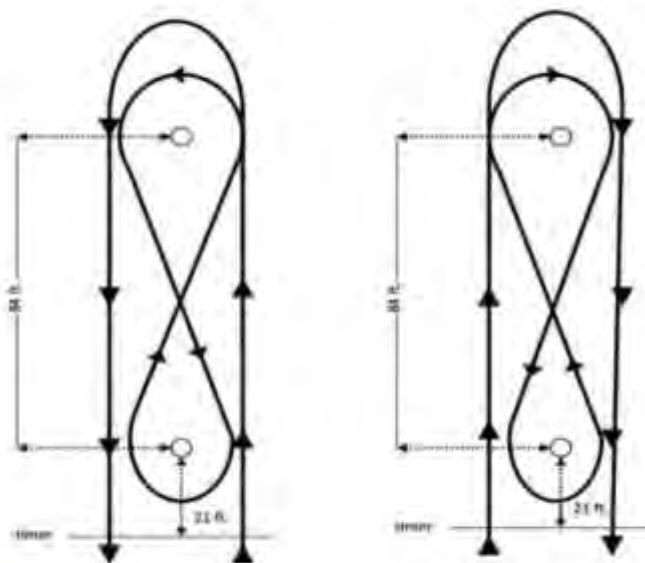

**BARREL RACING:**

- A. The cloverleaf pattern is designed to test the speed and maneuverability of the pony.
- B. The course should be measured exactly; if the course is too large for the available space, then the pattern may be reduced five yards at a time until the pattern fits the arena. Adequate space should be left between the barrels and any obstacle. The distance from barrel #3 to the finish line need not be reduced five yards at a time if there is adequate space for the pony to stop.
- C. A five second penalty will be added for each barrel knocked over.

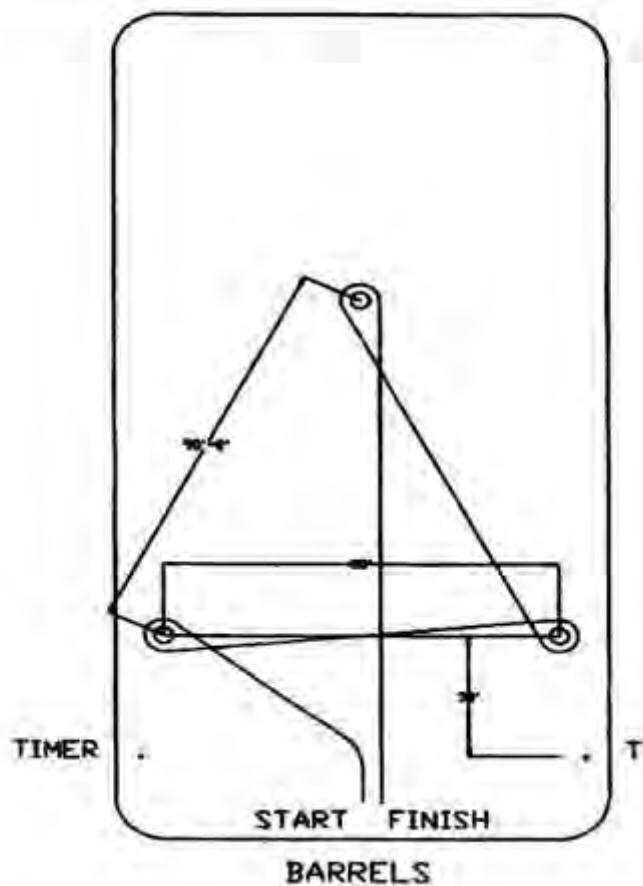

## DOWN AND BACK

---

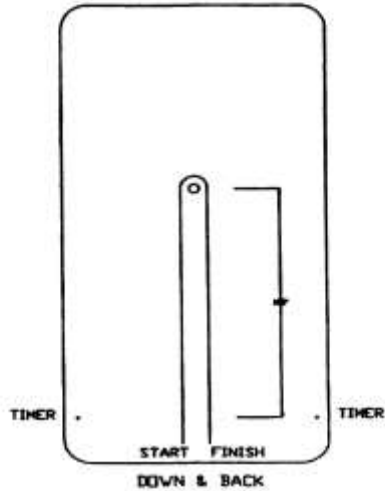

- A. Down and Back is designed to test the speed of the pony.
- B. One barrel should be placed at the far end of the arena, directly in front of the starting line, at one(100) feet.
- C. The rider may approach from either the left or right, going around the outside of the barrel proceeding to the finish line.
- D. Knocking over barrel results in a five (5) second penalty.

## FLAGS

A. The flag contest is designed to test the speed and maneuverability of the pony, in combination with the dexterity and control of the rider.

B. The barrels are placed as for barrel racing , with the run being made either to the right or left, outside of the barrels.

C. Buckets should be filled one inch from the top, full of sand or loose dirt to weight the bucket. A flag is placed in either of the buckets ( riders preference) . The rider runs to the outside of the barrel, picking up the flag, rounding the outside of the barrel on the far end of the arena, proceeding to the third barrel, where he/she places the flag in the bucket, and proceeds to the finish line.

D. There is a Five second penalty for each of the following infractions:

1. Rider fails to pick up flag
2. Flag stick doesn't remain in

the bucket

3. Knocking over any barrel
4. Knocking bucket off of barrel

E. The flag should be of a safe material, such as wood or plastic, approximately eighteen (18) inches in length, and one to one half inches in diameter

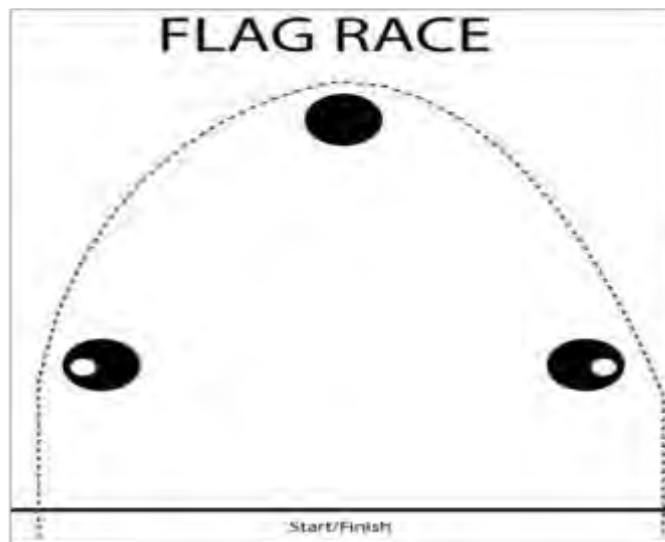

## SPEEDBALL

Barrel with  
bucket on  
top of barrel  
If available a  
lid with hole  
in top Ball  
has to go  
the bucket

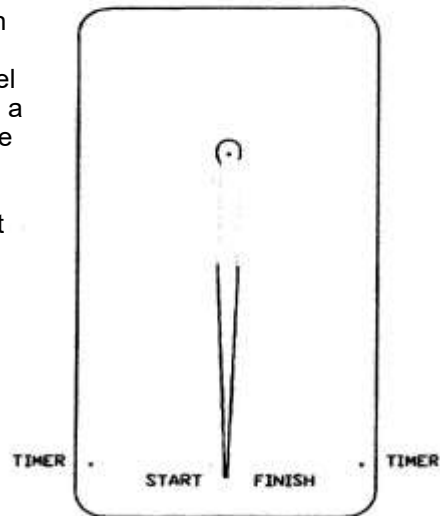

- A. Speedball is designed to test the speed of the pony and also the dexterity and control of the rider.
- B. The barrel is set at the end of the arena , with a bucket on top of it. Exhibitor runs down and puts ball in the small hole in top of bucket and runs back.
- C. A ten second (10) penalty occurs if the exhibitor does not get the ball in the bucket .
- D. A five second (5) occurs if the exhibitor knocks the barrel or the bucket over.



## PYLON ALLEY

---

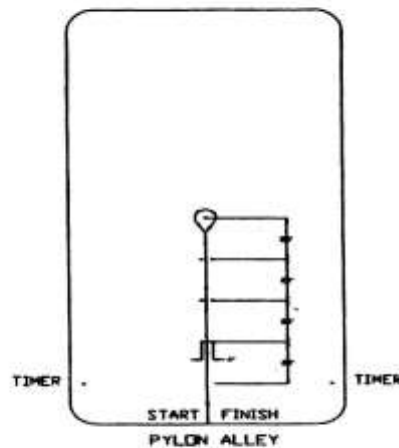

- A. Pylon Alley is designed to test the speed, maneuverability, and accuracy of the pony.
- B. The course involves a Sixty (60) foot alley from start/ finish line to the far end of the arena, where the pony must make a 180 degree turn around a cone, and return down the alley to the start/finish line. The alley should be Four (4) feet wide, and marked every Twenty(20) feet with cones or markers.
- C. There is a Five (5) second penalty for each marker which is knocked over.

**ORIGINAL KEYHOLE:**

A. Time starts when the pony crosses the starting line. They must enter the four-foot opening, turn around within the circle, and run out again through the four-foot opening. The clock is stopped when they again cross the starting line. Lime or flour is suggested to lay out the pattern.

B. Disqualification's are: If pony steps on or outside the markings of the circle or the opening

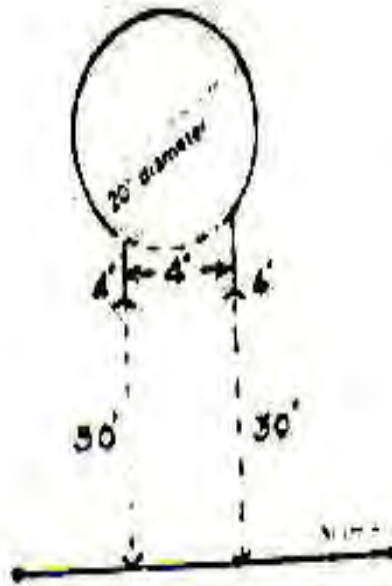

1. Three (3) poles are to be used in a 8' by 10' triangle (8x10). The center end pole is 126' from the timer.
2. The horse and rider run down between the 1st two poles and around the end pole (either direction) and back out between the 1st two poles.
3. Poles knocked over are a disqualification.
4. Failure to do a correct pattern is a disqualification.

### KEYHOLE RACE

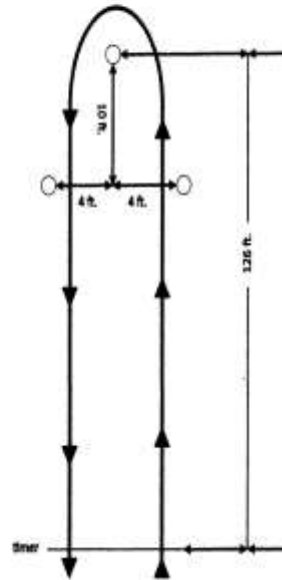

## NQPA WORLD WIDE POINTS PROGRAM

To receive awards and recognition for NQPA registered ponies and their owners. This printable flyer to use to take to the shows, have the show secretary sign and verify to accumulate points for awards. 0-10 Lifetime points will not receive any awards, but any points accumulated after 10; will start you and your animal towards, Coas, Roms, and many other awards given by the NQPA. States not included in this program are: Oh, Pa, Mi, IN, WV, and Ky. and Illinois Lists of classes eligible for these awards are listed in this rulebook.

POINT SYSTEM For the World Wide placings are up to 6

1-5 ponies in class .5 (1/2)

5-10 ponies in class 1 point

10-15 ponies in class 2 points

Points will be lifetime for both animal and owner Sheets must be sent in by October 1 of the current show year and yearly membership paid, and owner and animal in good standing.

Types of awards for this point system are : 10 Lifetime Points- Paper Rom 30 Lifetime points Medallion award 50 Life time points Superior Trophy Award When sending in your year end points report please keep a copy for yourself

### TO WHOM IT MAY CONCERN ANY HORSE SHOW SECRETARY

This sheet is a class result sheet for the following National Quarter Pony \_\_\_\_\_ and # \_\_\_\_\_ Show Secretary please sign and date so the following member may receive points for showing their animal at your show

SHOW NAME \_\_\_\_\_

SHOW DATE \_\_\_\_\_

NAME OF SECRETARY \_\_\_\_\_ Contact

# \_\_\_\_\_

Owners Name, address, and email or phone number \_\_\_\_\_

CLASS PLACING \_\_\_\_\_

CLASS PLACING \_\_\_\_\_

CLASS PLACING \_\_\_\_\_

CLASS PLACING \_\_\_\_\_

CLASS PLACING \_\_\_\_\_

CLASS PLACING \_\_\_\_\_

Owner –Please send this to NQPA P.O Box 171 Melrose, Ohio 45861

## NOTES

NQPA  
P.O. BOX 171  
MELROSE, OHIO  
45861